Methods for Stream Habitat Surveys Aquatic Inventories Project Natural Production Program: Oregon Department of Fish and Wildlife

INTRODUCTION

The Aquatic Inventories Project is designed to provide quantitative information on habitat condition for streams throughout Oregon. This information is used to provide basic information for biologists and land managers, to establish monitoring programs, and to direct or focus habitat restoration efforts.

Development of an Aquatic Inventories Project began within the Oregon Department of Fish and Wildlife (ODFW) in 1989 with sponsorship by the Restoration and Enhancement Program. Drafting of stream survey methods and implementation of field work began in 1990. The conceptual background for this work came from the experience of project staff and from interactions with Oregon State University, forest industry, and USFS PNW research scientists (Bisson et al. 1982, Grant 1986, Everest et al. 1987, Hankin and Reeves 1988, Moore and Gregory 1989, and Gregory et al. 1991). Significant contributions and review of these methods were provided by ODFW research staff, and from consultation with ODFW and United States Forest Service (USFS) biologists working on similar programs. Members of the Umpqua Basin Fisheries Restoration Initiative and the Oregon Forest Industry Council have provided additional review and consultation.

This methodology was designed to be compatible with other stream habitat inventories and classification systems (i.e., Rosgen 1985, Frissell et al. 1986, Cupp 1989, Ralph 1989, USFS Region 6 Level II Inventory 1992, and Hawkins et al. 1993). This compatibility is achieved by systematically identifying and quantifying valley and stream geomorphic features. The resulting matrix of measurements and spatial relationships can then be generalized into frequently occurring valley and channel types or translated into the nomenclature of a particular system. For example, information summarized at the reach level (valley width, channel type, slope, terrace height and width, sinuosity, width, depth, substrate, eroding banks, etc.) can be used to characterize the stream into one of the types described by Rosgen (1985) or to match the parameters collected in other quantitative (USFS) or historic (U.S. Bureau of Fisheries) surveys.

The process of conducting a stream survey involves collection of general information from maps and other sources and the direct observation of stream characteristics in the field. This information is both collected and analyzed based on a hierarchical system of regions, basins, streams, reaches, and habitat units. Supervisors are responsible for collecting the general information on regions and basins and for directing the activities of the survey crews. Survey teams will collect field data based on stream, reach and channel unit characteristics. Region and basin data will primarily come from ODFW-EPA region and sub region classifications, and from map analysis.

The following instructions and definitions provide the outline for these activities and a description of the tasks involved in conducting ODFW's stream habitat inventory.

Each field crew is comprised of two people with each member responsible for specific tasks. The "Estimator" will focus on the identification of channel unit characteristics. The "Numerator" will focus on the counts and relative distribution of several unit attributes and will verify the length and width estimates for a subset of units. The "Estimator" and "Numerator" share the responsibility for describing reach characteristics, riparian conditions, identifying habitat unit types, and for quantifying the amount of large woody debris. Crew members may switch responsibility for estimator or numerator when they start a new stream. They will not, however, switch estimator and numerator jobs on the same stream.

BASIN INFORMATION

Basin information is gathered prior to and during the course of the survey. Some of this information (primarily map work and regional classification) must be collected in the office. Most of this information is not the responsibility of the field crews. However, relevant comments by the survey crews should be included in their Field Books and on the Data Sheets. These summaries are used to group and classify streams and to provide general information for the final stream reports.

1. Basin name. Use the name of the large river commonly used to describe a region. For example, use McKenzie R for Lookout CR, not Willamette or Columbia.
2. Stream name. Use a standardized system of the name followed by descriptors of forks etc. Examples: Alsea R, Drift CR, Lobster CR, E FK. Spell out descriptive or non standard types such as Branch, Slough, or Swale. Spell out compass direction only for larger streams and when the usage is common, such as North Umpqua. Use the same name format on all data sheets.
3. Stream order, drainage area, and drainage density of the study stream. Determined from blue line tributaries (perennial and intermittent) shown on U.S.G.S. 7.5 minute topographic maps.
4. Elevation (m) at the confluence with the receiving channel and at the end of the survey.
5. ODFW-EPA Regions and Sub regions, geology, and soils of the basin.

6. Stream Flow. Location of USGS or other gauging stations. The location and stage height at any gauging station, marked bridge, or staff gauge will also be recorded during the survey.
7. General community structure and size composition of riparian vegetation. Identified by separate census or sample in each basin.
8. Description of fish species and stocks present, management concerns, and linkage to other databases or research projects.
9. Flow Regulation: Description of existing or proposed dams and diversions influencing the basin and segment.
10. General description of land use and ownership in the basin (e.g. managed timber, rural residential, agricultural, livestock grazing).
11. Contacts. Names, addresses, and phone numbers of key people to contact with respect to survey. Include ODFW district biologists, interested private individuals, landowners contacted for access, etc.

EQUIPMENT

1. Maps - 7.5 minute quad (1:24,000 scale) USGS topographic maps of the stream and basin. Road map coverage by county or fire district. Oregon Atlas and Gazetteer (Delorme Mapping).
2. Recording Materials - Waterproof field book, survey forms for each portion of the survey, waterproof paper, and pencils.
3. Clothes - Neoprene chest waders, wading shoes, and/or hip boots (non-slip soles of felt, studded "corkers", outdoor carpet or similar material is advised), rainwear, snag and thorn proof clothing appropriate for the weather.
4. Two-meter-long staff (marked in meters and tenths), compass, 60 meter fiberglass measuring tape, day pack, polarized glasses, thermometers, clinometer, clipboard, vest, flagging, permanent markers, and date-back camera, GPS unit.

See equipment page in appendix for a more complete description of survey equipment.

MAP WORK

Do not go into the field without a topographic map! Data that cannot be linked to the maps is essentially useless. Use the maps to orient to the stream and to identify the location of reach changes, named tributaries, roads, and bridge crossings. Mark all reach changes and important features on the map. Write the channel unit number on the map at the place that corresponds to the location of named tributary junctions, bridges, and other landmarks. Clearly mark where you start and end the survey.

A good correspondence between landmarks on the map and the data collected is an essential part of our survey effort. Information from the surveys will be utilized and integrated with Geographic Information System (GIS) analysis. Well documented and accurate maps are required for this process. In addition to a well marked map, it is essential that the habitat survey follow the USGS named stream on the topo map, regardless of the amount of flow.

An example of field entries on a topographic map is in the appendix (Page 32).

If using a GPS unit, record the Easting and Northing UTM coordinates at the beginning of the reach and at the end of all surveys. When reading the numbers from your GPS unit, the top number is the **Easting coordinate** and corresponds to small numbers along the top of your USGS quad map. The bottom number is the **Northing coordinate** and corresponds to similar numbers along the side of your USGS map. Your location should be where a vertical line from the Easting mark and a horizontal line from the Northing mark intersects.

FIELD BOOK

Maintain a succinct log of your activities in the field book. Each day, record the date and name of the stream where you worked. Enter the approximate distance covered and number of hours spent working on the stream. Keep track of your travel time separately.

Record relevant details about access to the stream, contact people from cooperating industry or agency groups, and people you contact to gain permission to survey. Record the names and phone numbers of people you may contact as you complete the survey.

Write a paragraph or so of general description for sections of each stream in the field book or on a separate stream report form. Pay particular attention to descriptions of the riparian zone, additional details concerning land use, or factors that influence the fish populations. This is the appropriate place to express your opinions. Other comments, sketches of complex features, suggestions, complaints, etc. are often useful.

PHOTOGRAPHS

A good photographic record of the stream survey provides additional information and documentation. Take pictures that typify reach changes, riparian zones, and other stream characteristics as described in the following sections of these instructions. Be sure that the date-back feature of the camera is functioning correctly and to turn off the flash. For each picture, record the channel unit number, date, time, and a description of the subject on the Photo Record sheet.

DATA SHEETS: REACH, UNIT-1, UNIT-2, WOOD, and RIPARIAN

REACH FORM

A reach is a length of stream defined by some functional characteristic. A reach may be simply the distance surveyed. More frequently, reaches are defined as: stream segments between named tributaries, changes in valley and channel form, major changes in vegetation type, or changes in land use or ownership.

Enter a new line on the reach data sheet at any significant change in any one of the reach variables (valley type, channel form, adjacent landform, valley width index, vegetation, or land use) *and/or* at the confluence with tributaries named on 7.5 minute topographic maps. When a new reach is identified by a named tributary, write the name in the Reach Note column. Also describe a new reach if an unnamed tributary contributes significant flow (approx. 15-20% of the total). Do not invent names for unnamed tributaries, instead identify them as Trib. 1, Trib. 2, etc. and record them on the data sheet and the map.

Changes in reach characteristics are used to verify survey location and to identify reach and stream segments within our basin classification system. Circle the variable that resulted in the new reach entry.

Flagging is used to mark specific points during a survey. Hang a strip of plastic flagging at each reach change, named tributary junction, and at riparian transects. Mark the flagging with the unit number, unit type, date, and "ODFW-AQ.-INV.". These flags will be used to locate specific reaches and units for fish sampling and to link units and locations for repeat habitat surveys. Randomly selected stream segments will be selected for repeat surveys during the field season. Results will be compared to check on variability between crews and for habitat changes at different stream flow.

The following sequence corresponds to the listing of variables on the data sheet:

1. **Date.**
2. **Reach.** The numbered sequence of reaches as they are encountered. Each reach is comprised of variable number of channel units.
3. **Unit Number.** Sequence number of the first unit recorded in a reach.

4. **Channel Form.** Determined by the morphology of the active channel, hill slopes, terraces, and flood plains. Identify the channel form and enter the appropriate two-letter code in this column. *Refer to Valley and Channel Classification in the appendix for definitions, allowable combinations, and examples.*

First look at the ratio of the active channel width to the valley width to determine the **Valley Width Index** (see pg. 7, # 6). This ratio determines if you are in a broad or narrow valley floor type. If the VWI is 2.5 or less you have a narrow valley type and if the VWI is greater than 2.5 you have a broad valley type.

Next, look at the types of land forms adjacent to the stream channel to characterize and complete your classification.

The channel is constrained when adjacent land forms restrict the lateral movement of the channel. In constrained channels, stream flows associated with all but the largest flood events are confined to the existing channel configuration.

- **Narrow Valley Floor Types (VWI \leq 2.5)**---Always constrained, defined by the characteristics of the constraining feature.

CB Constrained by **B**edrock (bedrock dominated gorge)
CH Constrained by **H**ill slope
CF Constrained by alluvial **F**an

- **Broad Valley Floor Types (VWI $>$ 2.5)**---The valley is several times wider than the active channel. The channel, however, may be either unconstrained or constrained depending on the height and configuration of the adjacent landforms.

1. **Unconstrained Channel** (terrace height is less than the flood prone height* and the floodprone width* is $>$ than 2.5X active channel width). Low terraces, overflow channels, and flood plains adjacent to the active channel.

US Unconstrained-predominantly **S**ingle channel.
UA Unconstrained-**A**nastomosing (several complex, interconnecting channels)
UB Unconstrained-**B**raided channel (numerous, small channels often flowing over alluvial deposits)

2. **Constrained Channel** (terrace height is greater than the flood prone height*). Adjacent land forms (terraces, hillslopes) are not part of the active flood plain.

CT Constraining **T**erraces. (terrace height $>$ floodprone height and floodprone width $<$ 2.5 X active channel width).
CA Constrained by **A**lternating terraces and hill slope. Same rule for terrace height but the channel may meander across the valley floor. The stream channel is confined by contact with hill slopes and high terraces.
CL Constrained by **L**and use (road, dike, landfill)

* See page 20 for floodprone height and width definitions.

5. **Valley Form.** General description of the valley cross section with emphasis on the configuration of the valley floor. Divided into types with a narrow valley floor (valley floor width (VWI) \leq 2.5 times stream active channel width (ACW)) and types with a broad valley floor (VWI $>$ 2.5 times ACW).

Narrow Valley Floor (VWI \leq 2.5)

SV	Steep V-Shaped valley or bedrock gorge (side slopes $\geq 60^\circ$).
MV	Moderate V-Shaped valley (side slopes $> 30^\circ$, $< 60^\circ$).
OV	Open V-Shaped valley (side slopes $\leq 30^\circ$).

Broad Valley Floor (VWI $>$ 2.5)

CT	Constraining Terraces. Terraces typically high and close to the active channel. Terrace surface is unlikely to receive flood flows and lacks water dependent (hydrophilic) vegetation.
MT	Multiple Terraces. Surfaces with varying height and distance from the channel. High terraces may be present but they are a sufficient distance from the channel that they have little impact.
WF	Wide-Active Flood plain. Significant portion of valley floor influenced by annual floods, and has water dependent vegetation (mesic meadow). Any terraces present do not impinge on the lateral movement and expansion of the channel.

Valley Form and Channel Form are related and can only occur in certain combinations. Possible combinations are shown on page 31, Table 1.

6. **Valley Width Index.** Ratio of the width of the active stream channel to the width of the valley floor. The Valley Width Index (VWI) is estimated for the reach by dividing the average *active channel width* into the average *valley floor width* (see diagram on page 20). In practice, the number of active channels that could fit across the valley floor. Also entered on UNIT 1 sheet at verified units.

Do not start a new reach for minor changes in valley width index. However, always start a new reach when the channel changes from VWI $<$ 2.5 to VWI $>$ 2.5; or VWI $>$ 5.

When the valley width changes repeatedly within a short distance, select an average value for the VWI. For example, when the valley floor gradually widens from a hillslope constrained reach to a broad valley reach, make one reach change, not new reach designations every few channel units.

It is possible to have an unconstrained channel but a VWI of 1. This may occur in some meadow reaches and other situations where the multiple channels and the floodplain spread across the entire valley floor.

Observations of valley floor surfaces and characteristics can be done as part of the riparian vegetation survey.

Getting out of the stream channel will help you to accurately estimate VWI, identify floodplain and terrace surfaces, and to classify reach types.

7. **Streamside Vegetation (Veg Class).** A two letter code based on the composition of riparian zone vegetation. Definitions of the riparian zone differ. Generally, we consider the vegetation observed in the area within one active channel width of either side of the channel to represent the riparian zone. The first letter identifies the plant community. The second part of the code will refer to the size of trees within identified dbh classes. Do not enter a size or age class for shrubs, brush, or grasses.

Example: riparian zone with 15-30 cm diameter alder = D15.

Separate entries are made for the dominant and subdominant plant communities as estimated from crown density. (Note: In some instances grass can be the dominant plant taxa).

Example: C30 (dominant) and G (subdominant) in ponderosa pine/grass communities.

Vegetation Type:

N	No Vegetation (bare soil, rock)
B	SageBrush (sagebrush, greasewood, rabbit brush, etc.)
G	Annual Grasses , herbs, and forbs.
P	Perennial grasses, sedges and rushes
S	Shrubs (willow, salmonberry, some alder)
D	Deciduous Dominated (canopy more than 70% alder, cottonwood, big leaf maple, or other deciduous spp.)
M	Mixed conifer/deciduous (approx. a 50:50 distribution)
C	Coniferous Dominated (canopy more than 70% conifer)

Size Class. Use groupings for the estimated diameter at breast height (dbh) expressed in centimeters of the dominant trees. Estimate diameter of young conifers below the first whorl of branches. Enter just the first number(s) of any choice.

1- 3	Seedlings and new plantings.
3-15	Young established trees or saplings.
15-30	Typical sizes for second growth stands. West side communities may have fully closed canopy at this stage.
30-50	Large trees in established stands.
50-90	Mature timber. Developing understory of trees and shrubs.
90+	Old growth. Very large trees, nearly always conifers. Plant community likely to include a combination of big trees, snags, down woody debris, and a multi-layered canopy.

These size classes correspond to dbh estimated in inches of: <1, 1-5, 6-11, 12-20, 21-35, and 36+ respectively.

8. **Land Use.** Determined from observations of terraces and hill slopes beyond the riparian zone. Code subdominant land use where appropriate. Separate entries for the dominant and subdominant land uses (i.e. PT (dominant) and HG (subdominant) = **P**artial cut **T**imber and **H**avy **G**razing).

AG	AG ricultural crop or dairy land.
TH	T imber H arvest. Active timber management including tree felling, logging, etc. Not yet replanted.
YT	Y oung F orest T rees. Can range from recently planted harvest units to stands with trees up to 15 cm dbh.
ST	S econd growth T imber. Trees 15-30 cm dbh in generally dense, rapidly growing, uniform stands.
LT	L arge T imber (30-50 cm dbh)
MT	M ature T imber (50-90 cm dbh)
OG	O ld G rowth F orest. Many trees with 90+ cm dbh and plant community with old growth characteristics.
PT	P artial cut T imber. Selection cut or shelterwood cut with partial removal of large trees. Combination of stumps and standing timber. If only a few live trees or snags in the unit, describe in note column.
FF	F orest F ire. Evidence of recent charring and tree mortality.
BK	B ug K ill. Eastside forests with > 60% mortality from pests and diseases. Enter bug kill as a comment on the unit sheet when it is observed in small patches.
LG	L ight G razing P ressure. Grasses, forbs and shrubs present, banks not broken down, animal presence obvious only at limited points such as water crossings. Cow pies evident.
HG	H avy G razing P ressure. Broken banks, well established cow paths. Primarily bare earth or early successional stages of grasses and forbs present.
EX	E Xclosure. Fenced area that excludes cattle from a portion of range land
GN	G ree N way. Designated Green Way areas, Parks (city, county, state).
UR	U Rban
RR	R ural R esidential
IN	I ndustrial
CR	C onservation area or wildlife R efuge.
MI	M ining
WL	W et L and.
NU	N o U se identified.
WA	Designated W ilderness A rea

9. **Water Temperature.** Stream temperature recorded at each reach change or a minimum of once per page of Unit 1 data. Record time. Note if temperature is °C or °F.

At named tributary junctions record the stream temperature just above the tributary and in the tributary. Identify and record each temperature in the appropriate line of the Unit 1 Note column.

10. **Stream Flow.** Description of observed discharge condition. Best observed in riffles. If a gauging station is present, be sure to record the stage height.

DR	DRy
PD	Puddled. Series of isolated pools connected by surface trickle or subsurface flow.
LF	Low Flow. Surface water flowing across 50 to 75 percent of the active channel surface. Consider general indications of low flow conditions.
MF	Moderate Flow. Surface water flowing across 75 to 90 percent of the active channel surface.
HF	High Flow. Stream flowing completely across active channel surface but not at bankfull.
BF	Bankfull Flow. Stream flowing at the upper level of the active channel bank.
FF	Flood Flow. Stream flowing over banks onto low terraces or flood plain.

11. **Location.** Township, range, section and quarter at the start of the reach. Use the following example as the format: T10S-R5W-S22SE.
12. **Photo Number and Time.** Take a photograph that shows the stream and riparian zone at each reach change. Record the exposure number and the time shown on the camera on the reach sheet and the photo record sheet.
13. **Reach Note.** Additional space for comments, names of tributaries, land ownership, and reach start location. Abbreviate by ownership code or use names of forest, timber companies, ranches, etc. when known.

P	Private
M	Municipal
C	County
T	Tribal
GN	GreenWay
FW	Oregon Department of Fish and Wildlife
BL	Bureau of Land Management
SF	State Forest
NF	National Forest
US	US Fish and Wildlife Service
WA	Wilderness Area

14. **Sketch.** Make a sketch of the channel and valley cross section for each reach in one of the boxes provided on the reach form. Identify the reach number in the box. Label and give approximate measurements and dimensions for important features. Record GPS UTM coordinates.

Example Reach Sheet

STREAM: EXAMPLE CREEK CREW: JANE DOE, JOHN DOE PAGE: 1 OF 1
 BASIN: N. SOMEWHERE R. USGS 7.5' MAP NAMES: CEGAR BUTTE

DATE	REACH #	UNIT NUMBER	CHANN. FORM		VALLEY FORM	VMT	VEG CLASS		DOM. SUB-DOM.	LAND USE		WATER TEMP	STEM FLOW	LOCATION TUNING REC-14	PHOTO #	REACH NOTE
			FORM	FORM			DOM.	SUB-DOM.		DOM.	SUB-DOM.					
7/2/98	1	1	CH	MV	Z	2	M30	D3	LT	YT	14°C	MF	T35-R5W-20N4	10/09/12	BEAR SURVEY 2	
7/2/98	2	97	CT	CT	3	3	M30	-	LT	RR	14°C	MF	T35-R5W-20N4	10/09/12	CONFERENCE w/ MAPLE CK	
7/3/98	3	180	US	MT	5	5	D15	S	YT	-	15°C	MF	T35-R5W-20N4	15/11/30	TRAB DET. - BLK CK.	
7/3/98	4	267	CH	MV	1.5	1.5	D30	S	ST	YT	15°C	MF	T35-R5W-15E	20/13/10	COUNTY ROAD # 17A	
7/7/98	5	391	CH	MV	1.5	1.5	D30	S	ST	YT	14°C	MF	T35-R5W-15N	22/11/15	TRAB DET. - BEAR CK.	
7/7/98	6	440	CH	SV	1.0	1.0	C30	-	LT	-	14°C	MF	T35-R5W-10N6	20/14/15		

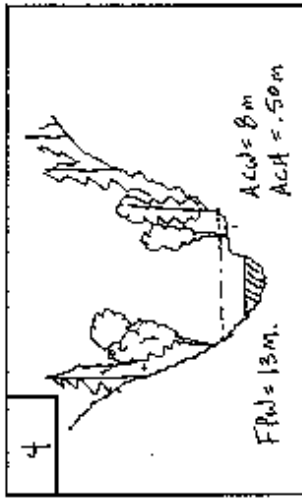
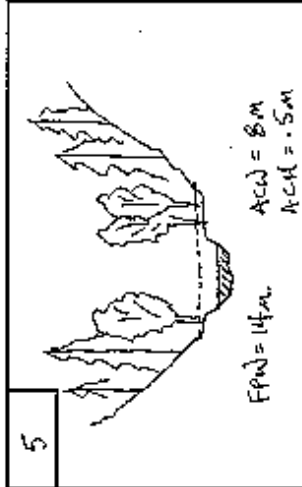
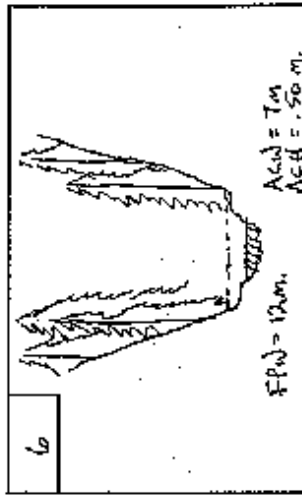
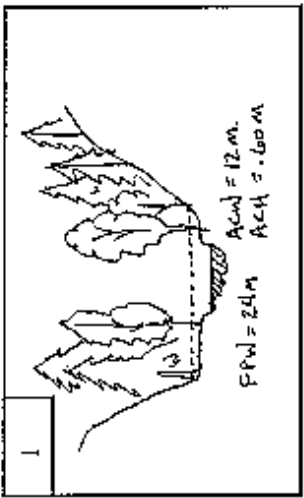
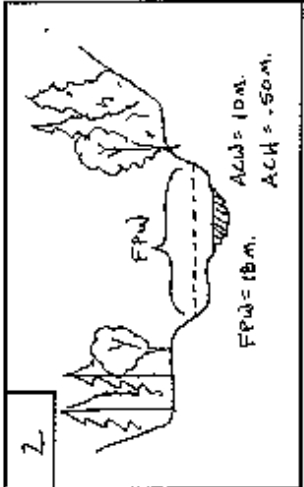
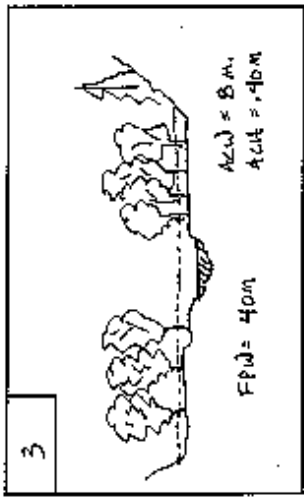

UNIT-1 FORM

This data sheet is completed by the "Estimator" member of the field crew.

- Crews work upstream, identifying and characterizing the sequence of habitat units.

- **At tributary junctions:**

Tributary channel junctions (confluence with a tributary) are identified and noted by comment code on the Unit 2 data sheet. Record the active channel width and temperature of the tributary in the note column.

At each channel junction, estimate the percent of total flow in each channel. Proceed up the named stream on the USGS topographic map regardless of flow. If neither channel is named, proceed up the channel with the greatest flow.

Survey the portion of tributaries that flow across the active channel up to the bank full level. Tributary channel units will be numbered and sequenced from the point where the tributary enters the main channel. Be sure to use the proper channel type code. Survey and record a minimum of one unit for each tributary and additional units (if applicable) that would become part of the main channel at bankfull flow. Mark the topo map referencing the unit number of the unit into which the tributary flows.

- **In braided channels:**

Continue upstream, always taking the channel with the greatest flow, until reaching the unit where the stream again forms a single channel. Backtrack, then survey the sequence of units in the secondary channel, then the sequence of units in the tertiary channel, etc.

For particularly complex areas, make a simple sketch in the field book showing the sequence of channel units (type and number) and location of channels.

1. **Reach.** The number of the reach; links unit data to reach data.
2. **Unit.** The sequential number describing the order of channel habitat units. A reach is comprised of many channel units.
3. **Unit Type.**

The concept of a channel habitat unit is the basic level of notation for our survey methodology. We subdivide the stream into two general classes of unit types: channel geomorphic units and special case units.

Channel geomorphic units are relatively homogeneous lengths of the stream that are classified by channel bed form, flow characteristics, and water surface slope. With some exceptions, channel geomorphic units are defined to be at least as long as the active channel is wide. Individual units are formed by the interaction of discharge and sediment load with the channel resistance (roughness characteristics such as bedrock, boulders, and large woody debris). Channel units are defined (in priority order) based on characteristics of (1) bedform, (2) gradient, and (3) substrate.

Special case units describe situations where, because of stream flow level or a road crossing, the usual channel geomorphic unit types do not occur. Special case units include dry or partly dry channels, and culverts.

GEOMORPHIC CHANNEL UNITS

Characteristic water surface slopes are given for each group of habitat unit types. However, channel bed form and flow characteristics are the primary determinant of unit classification. Use the unit's slope to help make determinations when the other characteristics are ambiguous.

POOLS (water surface slope usually zero)

- PP** **Plunge Pool:** Formed by scour below a complete or nearly complete channel obstruction (logs, boulders, or bedrock). Substrate is highly variable. Frequently, but not always, shorter than the active channel width.
- SP** **Straight scour Pool:** Formed by mid-channel scour. Generally with a broad scour hole and symmetrical cross section.
- LP** **Lateral scour Pool:** Formed by flow impinging against one stream bank or partial obstruction (logs, root wad, or bedrock). Asymmetrical cross section. Includes corner pools in meandering lowland or valley bottom streams.
- TP** **Trench Pool:** Slow flow with U or V-shaped cross section typically flanked by bedrock walls. Often very long and narrow with at least half of the substrate comprised of bedrock.
- DP** **Dammed Pool:** Water impounded upstream of channel blockage (debris jams, rock landslides).
- BP** **Beaver dam Pool:** Dammed pool formed by beaver activity. In most cases this will be preceded by a SD (step over beaver dam).

SUBUNIT POOLS

Alcoves, backwaters, and isolated pools are types of habitat subunits; generally not as long as the full channel width. They are, however, generally easy to identify and are important habitat types. Alcoves, backwaters, and isolated pools are formed by eddy scour flow near lateral obstructions.

- AL** **ALcove:** Most protected type of subunit pool. Alcoves are laterally displaced from the general bounds of the active channel. Substrate is typically sand and organic matter. Formed during extreme flow events or by beaver activity; not scoured during typical high flows.

BW **Backwater Pool:** Found along channel margins; created by eddies around obstructions such as boulders, root wads, or woody debris. Part of active channel at most flows; scoured at high flow. Substrate typically sand, gravel, and cobble.

IP **Isolated Pool:** Pools formed outside the primary wetted channel, but within the active channel. Isolated pools are usually associated with gravel bars and may dry up or be dependent on inter-gravel flow during late summer. Substrate is highly variable. Isolated pool subunits do not include pools of ponded or perched water found in bedrock depressions.

GLIDES

GL **Glide:** An area with generally uniform depth and flow with no surface turbulence. Low gradient; 0-1 % slope. Glides may have some small scour areas but are distinguished from pools by their overall homogeneity and lack of structure. Generally deeper than riffles with few major flow obstructions and low habitat complexity. There is a general lack of consensus regarding the definition of glides (Hawkins et al. 1993).

RIFFLES

RI **Riffle:** Fast, turbulent, shallow flow over submerged or partially submerged gravel and cobble substrates. Generally broad, uniform cross section. Low gradient; usually 0.5-2.0% slope, rarely up to 6%.

RP **Riffle with Pockets:** Same flow and gradient as Riffle but with numerous sub-unit sized pools or pocket water created by scour associated with small boulders, wood, or stream bed dunes and ridges. Sub-unit sized pools comprise 20% or more of the total unit area.

RAPIDS

RB **Rapid with protruding Boulders:** Swift, turbulent flow including chutes and some hydraulic jumps swirling around boulders. Exposed substrate composed of individual boulders, boulder clusters, and partial bars. Moderate gradient; usually 2.0-4.0% slope, occasionally 7.0-8.0%.

RR **Rapid over BedRock:** Swift, turbulent, "sheeting" flow over smooth bedrock. Sometimes called chutes. Little or no exposed substrate. Moderate to steep gradient; 2.0-30.0% slope.

CASCADES

- CB** Cascade over **B**oulders: Much of the exposed substrate composed of boulders organized into clusters, partial bars, or step-pool sequences. Fast, turbulent, flow; many hydraulic jumps, strong chutes, and eddies; 30-80% white water. High gradient; usually 3.5-10.0% slope, sometimes greater.
- CR** Cascade over **B**ed**R**ock: Same flow characteristics as Cascade over Boulders but structure is derived from sequence of bedrock steps. Slope 3.5% or greater.

STEPS

Steps are abrupt, discrete breaks in channel gradient. Steps are usually much shorter than the channel width. However, they are important, discrete breaks in channel gradient with 10->100% slope. Steps can separate sequential units of the same type.

Low steps (<0.3m high) in moderate to high gradient reaches formed by gravel and small cobbles on the face of transverse bars can usually be included in the next fast water unit upstream. However, small steps (<0.3m high) that separate pools may be important features in very low gradient reaches and should be recorded as individual habitat units.

Steps are classified by the type of structure forming the step.

- SR** Step over **B**ed**R**ock (include hardpan and clay steps)
SB Step over **B**oulders
SC Step over face of **C**obble bar
SL Step over **L**og(s), branches
SS Step created by **S**tructure (culvert, weir, artificial dams)
SD Step created by **B**eaver **D**am

⇒ Record the estimated height of the step in the note column and take a picture of any steps that are potential barriers to fish passage. (Note: always record a step height in the note column for the **SS** unit type regardless if a passage problem cannot be determined).

SPECIAL CASE UNIT TYPES

- DU** **D**ry **U**nit: Dry section of stream separating wetted channel units. Typical examples are riffles with subsurface flow or portions of side channels separated by large isolated pools. Record the length, active channel width, and all other variables for the dry areas.
- PD** **P**uddled: Nearly dry channel but with sequence of small isolated pools less than one channel width in length or width.
- DC** **D**ry **C**hannel. Section of the main channel or side channel that is completely dry at time of survey. Record all unit data, use active channel width for width.

- CC** **Culvert Crossing.** Stream flowing through a culvert. Record all data for metal bottom culverts. However, record the substrate of the surrounding fill material when estimating the composition of substrate material.
- ⇒ *Record the height from the culvert lip to the stream surface (drop), diameter, material, and shape of culvert in the note column. Take a picture of any culvert that is a potential fish barrier. If possible, have a depth staff or person in the photo to reference the step height.*
 - ⇒ *All Culvert Crossing unit types should have a Step Structure unit type immediately preceding it unless there is absolutely no drop to the water below. If a drop exists, record a step height in the note column regardless of the height. Write “no drop” in the note column if a drop does not exist.*

4. **Channel Type.** Channel ordering code based on channel by size and location. Orders the sequence of single, multiple, and side channels.

- 00 No Multiple Channels (all flow in one channel)
- 01 Primary Channel (of multiple channel reach or in the unit where a tributary enters the channel)
- 02 Secondary Channel (of multiple channel reach)
- 03 Tertiary Channel (of multiple channel reach)
Continue pattern for 04, 05, 06 level channels.
- 10 Isolated Pools, Alcoves, or Backwater Pools.
- 11 Primary channel of valley floor tributary. If the tributary has a name, write it in the note column.
- 12 Secondary channel of valley floor tributary.

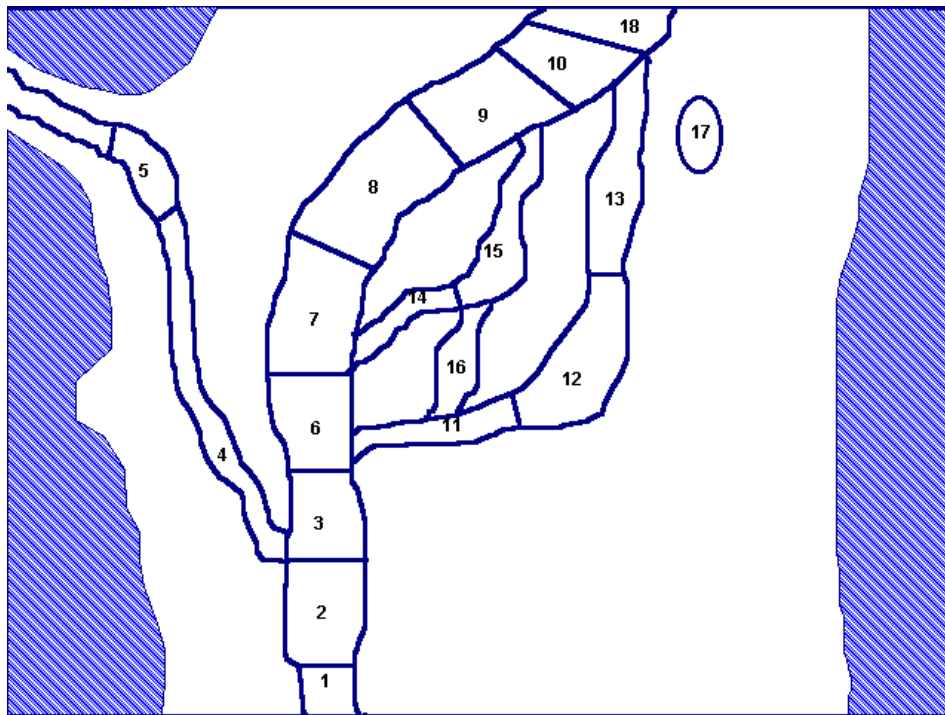

<u>UNIT NUMBER</u>	<u>UNIT TYPE</u>	<u>CHANNEL TYPE</u>	<u>% FLOW</u>
1	RI	00	100
2	LP	00	100
3	RB	01	90
4	RI	11	10
5	PP	11	10
6	RI	01	90
7	CB	01	80
8	RB	01	80
9	RI	01	90
10	LP	01	90
11	RI	02	10
12	LP	02	10
13	RB	02	10
14	RI	03	10
15	RP	03	10
16	RI	04	5
17	IP	10	0
18	CB	00	100

It is very important that the primary channel be identified with the proper code. This information is used in a critical step of the data analysis to calculate channel length and sinuosity.

The inventory considers the stream as the system of all channels that transport water down the drainage. The intention is to survey and quantify all aquatic habitats located within the valley floor. All active channels and unit types will be classified with a channel code and an estimate of the percent of total flow carried in each channel.

5. **Percent Flow.** Visual estimate of the relative amount of flow in the channel, in each channel where multiple channels occur, or the contribution to total flow from a tributary. Record 0% for alcove, backwater, and isolated pool unit types.

This is difficult to measure accurately. In the past, crews have tended to overestimate the contribution from tributaries. Don't be concerned about balancing your totals for flow to 100 percent. The information is used only to identify the relative contribution or distribution of flow. Record the active channel width (ACW) of the tributary in the note column as well.

6. **Unit Length.** Length of each unit in meters. The length is estimated every unit; it is estimated and verified every 10th unit.

To estimate the length of very long units, subdivide into lengths you are comfortable estimating and add them together. Do not pace the length of the unit. Except in very rare cases, no unit should be more than 100 to 150 meters long (with Oregon Plan surveys the maximum length of a unit will be 25m. for the 500 meter sites and 50m. for the 1000 meter sites).

Long units can usually be divided at points where the stream changes direction. When long units turn corners of the stream, create a new unit before the upstream member of the crew disappears from view. Back-to-back units of the same type are acceptable when following this "line of sight" rule. Use gradient changes to identify breaks in unit lengths.

⇒ Use equal effort to make good estimates on all units. Use the same technique on all units. Do not try to estimate more carefully on units you know will be verified.

7. **Unit Width.** Width of wetted channel (estimated every unit; estimated and verified every 10th unit). Measure the average width of the entire unit. On multiple wetted channel units, such as steps over bedrock where there are several wetted slots carved into the rock, record the sum of the wetted widths.

8. **Slope.** Gradient of water surface in the unit. Expressed as the percent change in elevation over the length of the unit. Estimated with a clinometer using the scale on the right side in the viewfinder.

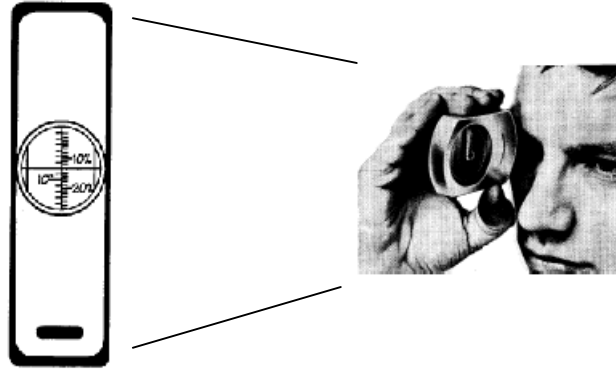

9. **Channel Shade.** (Shade Left and Shade Right on data sheet). Measured with the clinometer as the degrees (left side in the viewfinder) above horizontal to the top of riparian vegetation or land forms ($\leq 90^\circ$). Measured perpendicular to the channel unit on the left and right banks (see diagram below and on page 30). This variable requires integration of topographic shading and canopy closure.

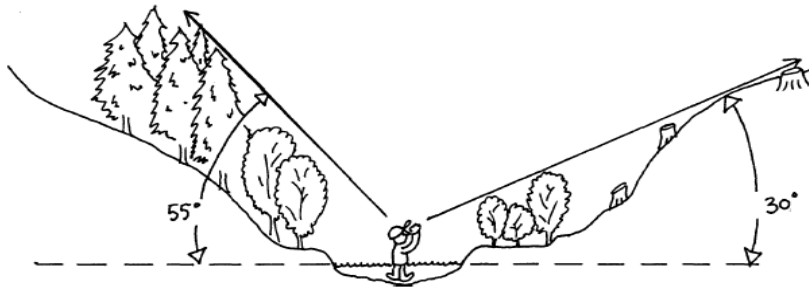

10. **Active Channel Height.** Vertical distance from the streambed to the top of the active channel. Determined by measuring the average water depth of fast water units or at pool tail crest of pools and adding the distance from water surface to the top of the active channel. Measure the height at every 10th unit and at change in reach type.
11. **Active Channel Width.** Distance across channel at "bank full" flow. Bankfull flow is the level the stream flow attains every 1.5 years on average. The boundary of the active channel can be difficult to determine; use changes in vegetation, slope breaks, or high water marks as clues. Sum the width of all active channels in multichannel situations. Measure the active channel width every 10th unit when verifying estimates and at start of new reaches.

Refer to the diagrams below and in the appendix for illustrations of active channel, floodprone, and terrace measures.

12. **Floodprone Height.** The floodprone height is determined by doubling the active channel height. The floodprone height is the maximum depth in the channel during a flood event occurring approximately every 50 years. Record twice the active channel height as the floodprone height, to the nearest 0.1 meter. Measure the floodprone height every 10th unit when verifying estimates and at start of new reaches.
13. **Floodprone Width.** Distance across the stream channel and/or unconstraining terraces at floodprone height. The floodprone width is the width of the valley floor inundated during a flood event occurring approximately every 50 years. Measure the floodprone width every 10th unit when verifying estimates and at start of new reaches.

If the floodprone width is less than 2.5 times the active channel width at that location, measure to the nearest 0.1 meter. If the floodprone width is greater than 2.5 times the active channel width at that location, simply estimate the floodprone width. The ratio of floodprone width to active channel width is necessary to determine the reach type and entrenchment ratio.

14. **Terrace Height.** The height from the streambed to the top of the high terrace. A high terrace is defined as the first terrace you encounter above the floodprone height. Measure every 10th unit and at reach changes.
15. **Terrace Width.** This is the inter-terrace distance measured from the first high terrace lip, across the stream channel, to the corresponding terrace lip on other side of the stream (TW in diagram below). Measure a terrace width and height if the following two conditions exist:
- 1) The terrace height is greater than the floodprone height
- AND**
- 2) The terrace width is less than 4 times the active channel width.

In multichannel situations, sum the inter-terrace width of all channels. Measure at every 10th unit (except for Oregon Plan surveys – see Appendix 1) and at start of new reaches.

16. **VWI** Valley Width Index. Same method as on the reach sheet (page 7). Additional estimates improve accuracy of average value.

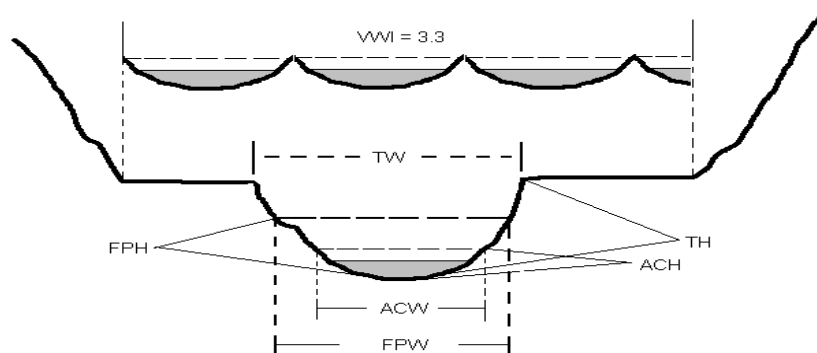

17. **Note.** Any pertinent additional information or items of interest (fish or wildlife observed, evidence of pollution or illegal dumping, description of channel structure, names of roads or tributaries, etc.).

UNIT-2 FORM

Information recorded by the "Numerator" member of each field crew.

1. **Unit Number.** Corresponds to number on "Estimator" sheet.
2. **Unit Type:** Corresponds to same type on "Estimator" sheet.
3. **Depth.** Maximum depth in pools, modal or typical depth in glides and fast water units. Measure to the nearest 0.05 meter as accurately as possible in pools. Probe the bottom with the depth staff to find the deepest point. Small differences in pool depth are significant.
4. **Depth at Pool Tail Crest:** Measure the maximum depth to the nearest 0.01 meter at the pool tail crest for every pool habitat unit, with the exception of subunit pools (BW, AL, IP). This location is at the point where the water surface slope breaks into the downstream habitat unit. This point is the deepest point along the hydraulic control feature that forms the pools. For beaver ponds unit type (**BP**) that have no water flowing over the top of the dam yet there is subsurface flow through the sticks and logs of the dam, record the PTC depth as 0.01 meter.
5. **Verified Length and Width.** The measured length and width of the habitat unit. Taken at every 10th unit and called "verified units" because the actual measurements are used to calibrate the estimates made on each unit. Where a particular unit type is rare, additional measurements may be necessary; simply write in the values over the shaded part of the data sheet.

*Remember to hang a flag at every third channel metric.
These correspond with the riparian transect.*

6. **Substrate.** Percent distribution by streambed area of substrate material in six size classes: silt and fine organic matter, sand, gravel (pea to baseball; 2-64mm), cobble (baseball to bowling ball; 64-256mm), boulders, and bedrock. Estimate distribution relative to the total area of the habitat unit (wetted area). Round off each class to nearest 5 percent

Do not worry about totaling your estimates to 100 percent; this will be done during analysis. Be sensitive to the difference between surface flocculants and other fine sediment. Fine sediment that covers and embeds gravel and cobble should be part of your estimate. A thin layer of low density fine material over bedrock or boulders should not be included.

SL (step over log) and CC (culvert crossing) unit types can create confusion. Estimate the distribution of the surrounding and/or supporting substrate to the best of your ability. For open bottom culverts, estimate the substrate as you would a normal habitat unit.

7. **Boulder Count.** Count of boulders greater than 0.5 m in average diameter. Within this size class, include only the boulders that have any portion protruding above the water surface and those at the margin of the wetted channel. In dry units and dry channels, estimate the boulder count by including boulders with sizes and orientation similar to those counted in wetted units of the same stream.
8. **Percent Actively Eroding Bank.** Estimate the percent of the lineal distance of both sides of the habitat unit that is actively eroding at the active channel height. Active erosion is defined as actively, recently eroding, or collapsing banks and may have the following characteristics: exposed soils and inorganic material, evidence of tension cracks, active sloughing, or superficial vegetation that does not contribute to bank stability.
9. **Percent Undercut Bank.** An estimate of the percent of the perimeter of the habitat unit composed of undercut banks. Estimate at the margins of the wetted channel as an index of cover habitat.
- Look for areas that provide good hiding cover for fish. Typically, if the undercut portion extends along the bank for a meter or more, include it in your estimate. Include areas undercut beneath root wads.*
10. **Comment Codes.** Comments identifying important features. Enter as many codes as appropriate. Separate items that apply to the left bank (looking upstream) from those for the right bank using a slash (/). *If a code does not exist for an observation, do not invent a code. Write a description in the note column if necessary.*
- BC** **Bridge Crossing.** Record road name or number in note.
 - BD** **Beaver Dam.** Helps to identify steps created by beavers.
 - BK** **Bug Kill.** Patches of insect or disease tree mortality.
 - BV** **BeaVer Activity** (beaver den, cut trees, etc.)
 - CC** **Culvert Crossing.** Same as Bridge Crossing except the stream passes through a culvert. Record road name or number.
 - CE** **Culvert Entry.** Tributary entering through culvert. Record diameter, length, slope, and height of drop.
 - CS** **Channelized Streambanks.** Rip-rap or other artificial bank stabilization and stream control.
 - DJ** **Debris Jam.** Accumulation of large woody debris that fills the majority of the stream channel and traps additional debris and sediment.
 - FC** **Fence Crossing.**
 - GS** **Gauging Station.**
 - HS** **Artificial Habitat Structure.** Describe type: gabion, log weir, cabled or uncabled LWD, etc. in note. If a habitat structure spans across several habitat units record it only once. Put the comment code in the unit that is most affected by the habitat structure.
 - MI** **Mining**
 - PA** **Potential Artificial Barrier.** Potential artificial or human created barrier to upstream or downstream migration of fish. Document height, take photos and notes.

Comment Codes (continued)

- PN** **Potential Natural Barrier.** Potential natural barrier to upstream or downstream migration of fish. Document height, take photos and notes.
(Note: Barriers are relative to stream size and fish species encountering them. Consider these variables when using this comment code).
- RF** **Road Ford.** Road that crosses within the active channel of the stream (no bridge).
- SD** **Screened Diversion** (pump or canal). Give some indication of size or capacity.
- SS** **Spring or Seep.** Usually small amounts of flow (<5% of total flow) directly entering from hillslope. For large springs, estimate the contribution to flow.
- TJ** **Tributary Junction** with named and unnamed tributaries. Use the **TJ** class only for tributaries with clearly developed channels.
- UD** **Unscreened Diversion** (pump or canal). Give some indication of size or capacity.
- WL** **WildLife** use of stream or riparian zone (note species) This code refers to anything except fish species. Record fish observations only in the note column. Identify species if possible.

Mass Movement: Use a two-part code. The first letter identifies the type of mass movement failure. The second letter evaluates the apparent activity of the failure. (Example: AI = inactive debris avalanche.)

Type:

- E** **Earthflow:** general movement and encroachment of hill slope upon the channel. These can be identified by groups of unusually leaning trees on a hillslope
- L** **Landslide:** failure of locally adjacent hill slope. Usually steep, broad, often shaped like a half oval, with exposed soils.
- A** **Avalanche:** failure of small, high gradient, tributary. Often appear "spoon shaped" looking upslope. Water may flow in these intermittent or ephemeral channels that contribute alluvial soils and debris.

Condition:

- A** **Active:** contributing material now.
- I** **Inactive:** evidence of contribution of material during previous winter or high flows.
- S** **Stabilized:** vegetated scars, no evidence of recent activity.

11. **Note.** Additional information that describes the habitat unit, comment code, riparian vegetation, fish species present, measurements of steps, culverts, barriers, etc.

WOOD FORM

Objective of this effort is to apply a standardized and consistent methodology to obtain quantitative estimates of wood volume and distribution within stream reaches. Information will be used to evaluate effects on fish habitat and channel structure and to make quantitative comparisons between streams.

- Minimum size to consider is 15 cm diameter by 3 m length. Exception is root wads with cut ends which may be less than 3 m long.
- Collect data for all wood that meets the minimum size criteria. Do not attempt to evaluate its effectiveness as fish habitat.
- Count all dead pieces that are within, partially within, or suspended over the active channel, regardless of height above channel. Any live woody material is not counted.
- Estimate the entire length of all pieces; include portion outside the active channel.
- Use additional lines for each unit when more than one configuration, type, or size class of wood is present.
- Indicate grouping of pieces in individual accumulations and jams by drawing brackets around the appropriate rows in the note column.
- Location of all wood pieces within a jam is identified by the primary location or function of the jam.
- Make no entry for units where woody debris is absent.

1. **Unit Number.**

2. **Unit Type.**

3. **Debris Configuration.**

- S** Single piece.
A Accumulation. Two to four pieces.
J Jam. More than four pieces.

4. **Debris Type.**

- N** Natural. Broken ends or whole tree.
C Cut end.
A Artificial. Part of man-made structure
RN Root wad attached to Natural bole.
RC Root wad with opposite end **C**ut.

5. Debris Location.

- S** Side of the channel.
- M** Mid-channel
- I** Island. At upstream end of mid-channel island.
- F** Full channel. Completely across channel within active channel. Pieces may be above the wetted channel at the time of the survey. When part of a jam, include all pieces regardless if they are touching the water, piled up, or submerged.
- O** Over channel. Suspended over the active channel with the ends above the active channel. Include debris with suspended bole but with branches in water.

6. **Diameter Class.** Estimate diameter of each piece at 2 meters above the base of the stem. Assign each piece or group of pieces to the closest size class (0.15, 0.30, 0.45). For pieces greater than 0.60 diameter be as accurate as possible when determining diameter and length. Measure diameter in meters.
7. **Length Classes.** Count and tally the number of pieces within each length class. Root wad less than three meters long (usually with a cut end) is a special case.
8. **Wood Note.** Note the tree species if known and any other information or assessments of the source, influence, or character of the woody debris.

*When estimating very large amounts of wood in debris jams, visually group it into length and diameter classes then count and tally onto the data sheet. Assign all jams to one unit number. Indicate in the note column if the jam spans more than one unit. Do not try to evaluate one piece at a time. **Record and tally all countable pieces.***

RIPARIAN FORM

Purpose: The riparian inventory is designed to provide additional quantitative information on the species composition, abundance, and size distribution of riparian zone vegetation.

The riparian inventory will consist of a type of belt transect extending across the riparian zone perpendicular to the stream channel on each side.

Frequency: Transects will be conducted at least once every thirty units (once per unit page – except for Oregon Plan surveys – see Appendix 1) and at the beginning of all reaches. **Every** identified reach has to have at least one riparian transect. Begin the transect exactly where the new unit or new reach starts. Do not select starting point elsewhere in the unit because of ease of access or to get a "better" sample. **The location of each transect must be marked on the 7.5 minute topo map. Transects must occur at least every 1 kilometer.** Discuss transect spacing with your field supervisor if you are surveying a large stream.

Transects will begin at the margin of the active channel or where the initial band of riparian trees starts, whichever comes first. The transects will be perpendicular to the main axis of the stream and extend 30m as measured on the ground. The transects will be 5m wide and will be subdivided into three 10 meter long sections or zones (see the following diagrams).

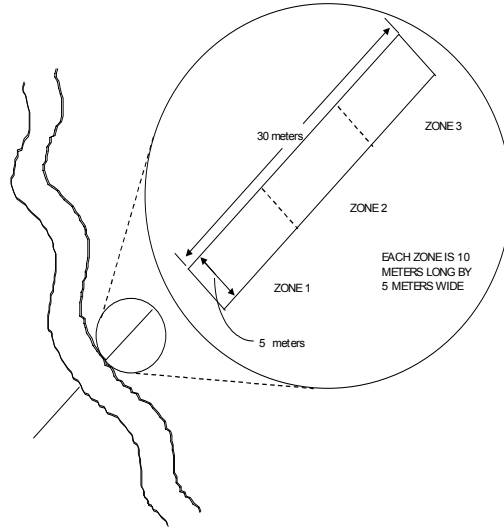

One member of the survey crew will extend the tape measure out from the stream channel. The other crew member will follow and use the depth staff to determine if trees are within the area to be counted. Any tree that can be touched with the depth staff extended from either side of the body (practice the amount of reach you require to measure a 5m band) should be counted.

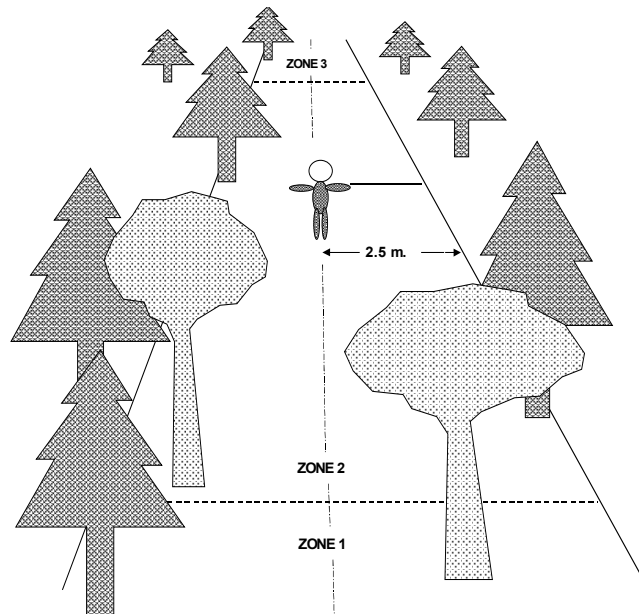

After the crews become very familiar with the method, particularly the dimensions of the sections and the size classes of trees they may visually estimate and count in difficult situations. There is no need, for example, to try and walk through 30m of blackberry bramble to measure the diameter of one or two alder trees. Likewise, it is not necessary to climb steep slopes to measure tree diameters.

Complete the following entries on the Riparian form:

1. **Unit Number.** The unit that begins where the transect is established.
2. **Side.** Left or right side of the channel, looking upstream.
3. **Zone.** Subdivision of the transect.
 - 1 0-10 meters
 - 2 10-20 meters
 - 3 20-30 meters
4. **Surface.** Geomorphic surfaces observed within the zone. If more than one surface is observed, record the more dominant feature and make a note of the other feature in the note column. Note length of each feature. Explain any ambiguous observations in the note column.

FP	FloodPlain
LT	Low Terrace (height is < Flood Prone Height)
HT	High Terrace (height is > Flood Prone Height)
HS	HillSlope
SC	Secondary Channel
TC	Tributary Channel
IP	Isolated Pool or unconnected valley wall channel.
WL	WetLand bog or marsh with no obvious channel.
RB	Road Bed (indicate surface type in note column i.e. paved, rock)
RG	Railroad Grade
RR	Rip Rap
5. **Slope.** Measure the percent slope (NOT degrees) of the dominant surface in the zone.
6. **Canopy Closure.** The percent canopy closure estimated by looking up while standing in the middle of the zone. Include the influence of both conifer and hardwood species. Estimate within broad categories (20% increments).
7. **Shrub Cover.** The percentage of ground cover provided by shrubs. Include blackberry, salmonberry, devils club, willow, sage, etc. Small trees (seedlings and samplings less than 8 feet high) should be included in shrub cover. Estimate within broad categories (20% increments).
8. **Grass and Forb Cover.** The percentage of ground cover provided by grasses, ferns, moss, herbs, sedges, rushes, etc. Estimate within broad categories (20% increments).
9. **Tree Group.** Conifer or hardwood.
10. **Count.** Tally of trees by diameter class. Measured in centimeters as: 3-15, 15-30, 30-50, 50-90, or 90+.
11. **Riparian Note.** Optional comments that describe tree species or the plant community, large woody debris, or characteristics of snags or old stumps. Note presence or absence of large down wood in riparian zone. Record the riparian photo number and time in this column as well.

LITERATURE CITED

- Bisson, P. A., J. A. Nielsen, R. A. Palmason, and E. L. Grove. 1982. A system of naming habitat types in small streams, with examples of habitat utilization by salmonids during low stream flow. Pages 62-73 *in*: N. B. Armantrout, ed. Acquisition and utilization of Aquatic Habitat Inventory Information. Western Division, American Fisheries Society, Portland OR.
- Cupp, C. E. 1989. Stream corridor classification for forested lands of Washington. Hosey and Assoc. Bellevue, WA 46 p.
- Everest, F. H., R. L. Beschta, J. C. Scrivener, K. V. Koski, J. R. Sedell, and C J. Cederholm. 1987. Fine sediment and salmonid production: A paradox. Pages 98-142 *In*: E. O. Salo and T. E. Cundy eds., Streamside Management: Forestry and Fishery Interactions. Contribution No. 57. Institute of Forest Resources, University of Washington, Seattle, Washington.
- Frissell, C. A., W. J. Liss, C. E. Warren, and M. D. Hurley. 1986. A hierarchical framework for stream habitat classification: viewing streams in a watershed context. *Environ. Manage.* 10: 199-214.
- Grant, G. E. 1988. Morphology of high gradient streams at different spatial scales, Western Cascades, Oregon. Pages 1-12 *in*: Shizouka Symposium on Geomorphic Change and the Control of Sedimentary Load in Devastated Streams, Oct. 13-14, 1988. Shizouka University, Shizouka, Japan.
- Gregory, S. V., F. J. Swanson, and W. A. McKee. 1991. An ecosystem perspective of riparian zones. *BioScience* 40: 540-551.
- Hankin, D. G., and G. H. Reeves. 1988. Estimating total fish abundance and total habitat area in small streams based on visual estimation methods. *Can. J. Fish. Aquat. Sci.* 45: 834-844.
- Hawkins, C. P., J. L. Kershner, P. A. Bisson, M. D. Bryant, L. M. Decker, S. V. Gregory, D. A. McCullough, C. K. Overton, G. H. Reeves, R. J. Steedman, and M. K. Young. 1993. A hierarchical approach to classifying stream habitat features at the channel unit scale. *Fisheries* 18 (6): 3-12.
- Moore, K. M., and S. V. Gregory. 1989. Geomorphic and riparian influences on the distribution and abundance of salmonids in a Cascade Mountain Stream. Pages 256-261 *in*: D. Abell, ed., Proceedings of the California Riparian Systems Conference; 1988 September 22-24, 1988; Davis, CA. Gen. Tech. Rep. PSW-110. Berkeley CA: Pacific Southwest Forest Range and Experiment Station, U.S.D.A.
- Ralph, S. C. 1989. Timber/Fish/Wildlife stream ambient monitoring field manual. Center for Streamside Studies, University of Washington. Seattle, Washington.
- Rosgen, D. L. 1985. A stream classification system. Pages 95-100 *in*: Riparian Ecosystems and Their Management; Reconciling Conflicting Uses. First North American Riparian Conference, April 16-18, 1985, Tucson, Arizona. USDA Forest Service. Gen. Tech. Rep. RM-120. Fort Collins, Colorado.

ADDITIONAL LITERATURE

- Dambacher, J.M. and K.K. Jones. 1997. Stream habitat of juvenile bull trout populations in Oregon and benchmarks for habitat quality. Pages 353-360 in Mackay, W. C., M. K. Brewin, and M. Monita, editors. Friends of the bull trout conference proceedings. Bull Trout Task Force (Alberta), c/o Trout Unlimited Canada, Calgary.
- Dolloff, C. A., H. E. Jennings, and M. D. Owen. 1997. A comparison of basinwide and representative reach habitat survey techniques in three southern Appalachian watersheds. *North American Journal of Fisheries Management* 17:339-347.
- Hankin, D. G. 1984. Multistage sampling designs in fisheries: applications in small streams. *Canadian Journal of Fisheries and Aquatic Sciences* 41:1575-1591.
- Hannaford, M. J., M. T. Barbour, and V. H. Resh. 1997. Training reduces observer variability in visual-based assessments of stream habitat. *Journal of the North American Benthological Society* 16 (4): 853-860.
- Jones, K.K. and K.M.S. Moore. In Press. Habitat assessment in coastal basins in Oregon: implications for coho salmon production and habitat restoration. In Knudsen, E., editor. Proceedings of the Sustainable Fisheries Conference. North Pacific International Chapter of the American Fisheries Society. April 26-30, 1996.
- Jones, K.K., and four co-authors. 1998. Status of Lahontan cutthroat trout in the Coyote Lake Basin, southeast Oregon. *North American Journal of Fisheries Management*. Expected publication in May issue.
- Keller, E. A. and W. N. Melhorn. 1978. Rhythmic spacing and origin of pools and riffles. *Geological Society of America Bulletin* 89:723-730.
- McKinney, S. P., J. O'Conner, C. K. Overton, K. MacDonald, K. Tu, and S. Whitwell. 1996. A characterization of inventoried streams in the Columbia River basin. Aqua-Talk. R-6 Fish Habitat Relationship Technical Bulletin 11, Portland, Oregon.
- McIntosh, B. A., J. R. Sedell, N. E. Smith, R. C. Wissmar, S. E. Clarke, G. H. Reeves, and L. A. Brown. 1994. Historical Changes in fish habitat for select river basins of eastern Oregon and Washington. *Northwest Science* 68 (Special Issue):36-53.
- Moore, K. M. S., K. K. Jones, and J. M. Dambacher. 1997. Methods for stream habitat surveys. Oregon Department of Fish and Wildlife, Information Report 97-4, Portland, Oregon.
- Reeves, G. H., L. E. Benda, K. M. Burnett, P. A. Bisson, and J. R. Sedell. 1995. A disturbance-based ecosystem approach to maintaining and restoring freshwater habitats of evolutionarily significant units of anadromous salmonids in the Pacific Northwest. *American Fisheries Society Symposium* 17:334-349.
- Roper, B. B., and D. L. Scarnecchia. 1995. Observer variability in classifying habitat types in stream surveys. *North American Journal of Fisheries Management* 15:49-53.

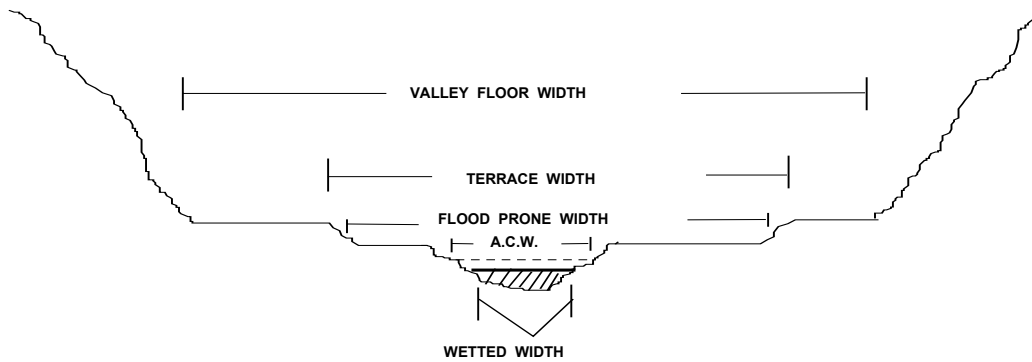
APPENDIX 1: MEASUREMENTS AND MAP EXAMPLE**ACTIVE CHANNEL, FLOOD PRONE, TERRACE, AND VALLEY FLOOR WIDTHS****CHANNEL SHADE**

Use of the clinometer to estimate topographic and vegetative shading.

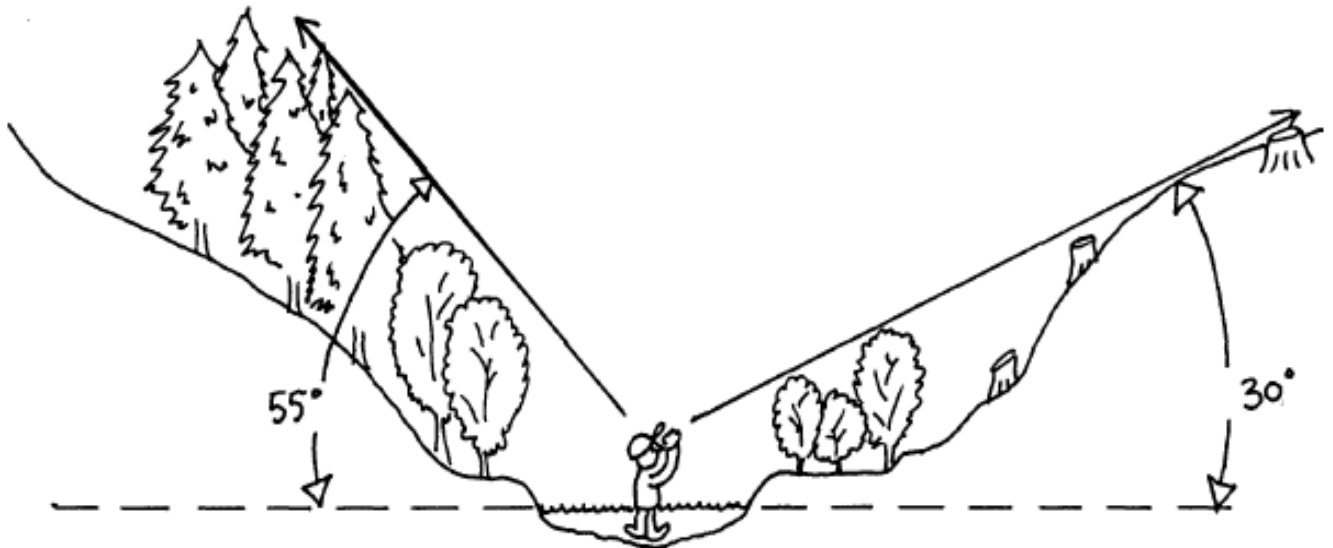

EXAMPLE OF MAP DETAIL

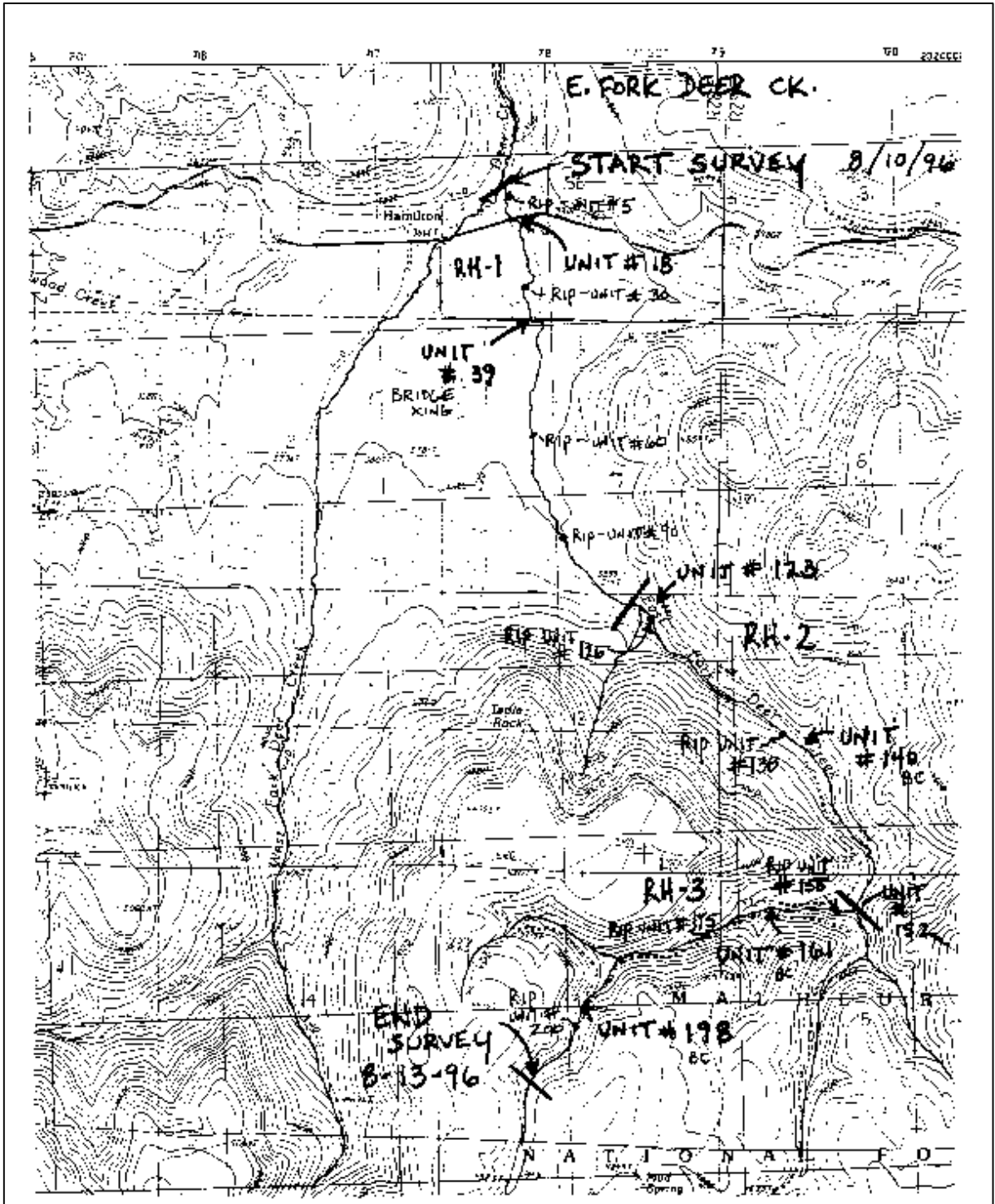

APPENDIX 2: CHANNEL AND VALLEY FORM SUMMARIES

TABLE 1: POSSIBLE REACH – CHANNEL – VALLEY COMBINATIONS

CHANNEL FORM	VALLEY FORM					
	VWI < 2.5			VWI > 2.5		
	NARROW VALLEY FLOOR			BROAD VALLEY FLOOR		
CHANNEL CONSTRAINED:	STEEP V	MOD. V	OPEN V	HIGH TERRA	MULT. TERR	FLOODPLAIN
BEDROCK	CB - SV	CB - MV	CB - OV			
HILLSLOPE	CH - SV	CH - MV	CH - OV			
ALT. HILLSLOPE TERRACE				CA - CT	CA - MT	
HIGH TERRACE				CT - CT	CT - MT	
LAND USE				CL - CT	CL - MT	CL-WF
CHANNEL UNCONSTRAINED:						
SINGLE CHANNEL				US - MT	US - WF	
ANASTOMOSING				UA - MT	UA - WF	
BRAIDED CHANNEL				UB - MT	UB - WF	

Check the valley form description against the Valley Width Index.
If it does not match, is it because the reach was not described properly,
or was the ACW determined incorrectly?

Does the terrace height work with the channel and valley form calls?
Remember that a high terrace more than one ACW away from the channel on both
sides is not considered constraining.

Streamside terraces are frequently present within narrow valley floors, however,
remember that when $VWI < 2.5$, it is the hillslope or bedrock that constrains the channel.

In rare cases, notably flooded bogs, multiple channel wetlands, or flooded valley bottoms
due to beaver activity, the $VWI = 1$ but the channel is actually unconstrained. Make a
note and explain.

Use the spaces on the reach form to make diagrams of the reach cross section.
Label your drawings so that ambiguous or exceptional reach types can be understood.

VALLEY FORM

NARROW VALLEY FLOOR

VWI < 2.5

BROAD VALLEY FLOOR

VWI > 2.5

OV

OPEN V-SHAPED

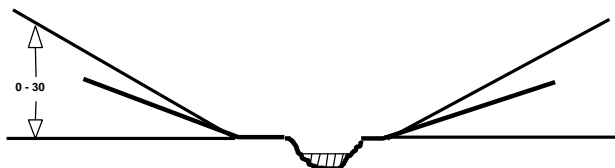

CT

CONSTRAINING TERRACES

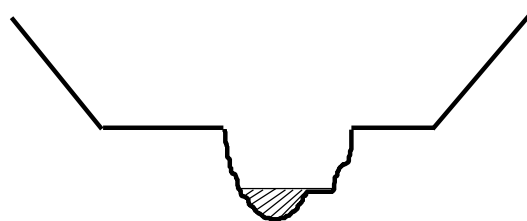

MV

MODERATE V-SHAPED

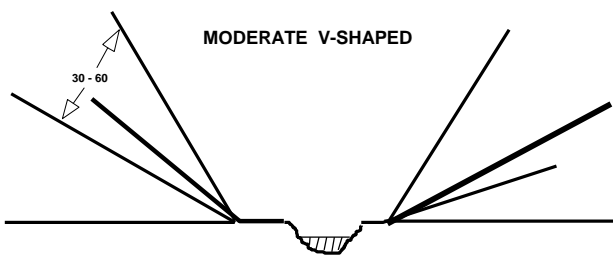

MT

MULTIPLE TERRACES



SV

STEEP V-SHAPED

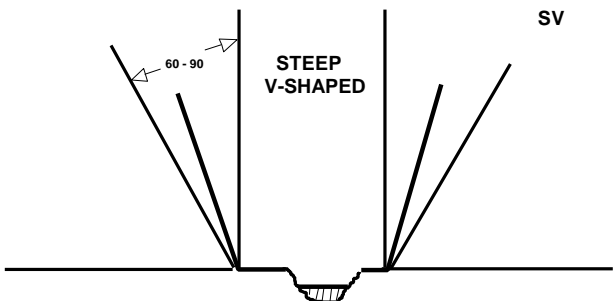

WF

WIDE - ACTIVE FLOODPLAIN

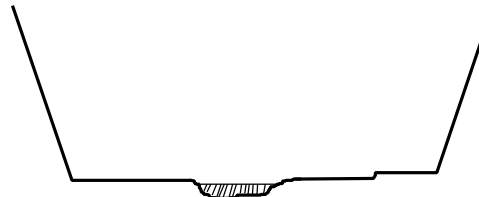

CHANNEL FORM

HILLSLOPE CONSTRAINED

VALLEY FLOOR WIDTH < 2.5x ACTIVE CHANNEL WIDTH

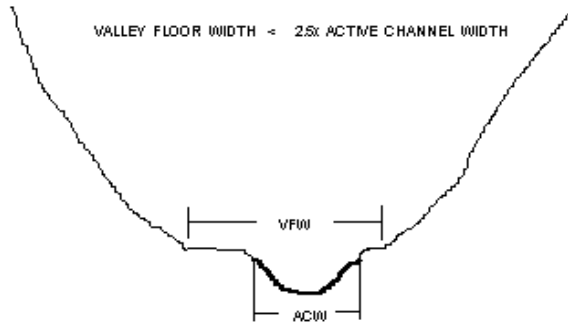

CH

UNCONSTRAINED

VALLEY FLOOR WIDTH > 2.5x ACTIVE CHANNEL WIDTH

FLOOD PRONE WIDTH > 2.5x ACTIVE CHANNEL WIDTH

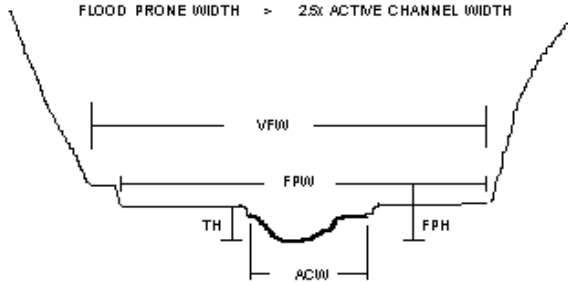

US

UA

UB



TERRACE CONSTRAINED

VALLEY WIDTH > 2.5x ACTIVE CHANNEL WIDTH

TERRACE HEIGHT > FLOOD PRONE HEIGHT

FLOOD PRONE WIDTH < 2.5x ACTIVE CHANNEL WIDTH

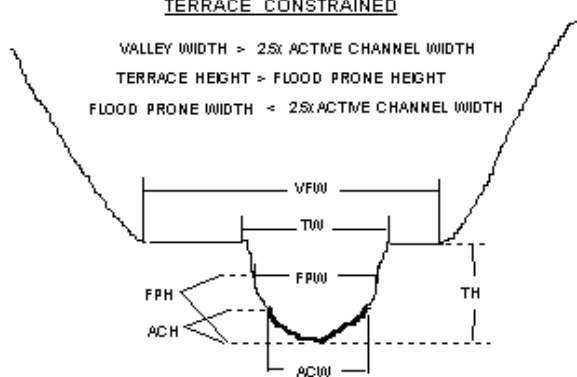

CT

CHANNEL FORM (cont.)

BEDROCK CONSTRAINED

VALLEY FLOOR WIDTH < 2.5x ACTIVE CHANNEL WIDTH

BEDROCK COMPRISES > 50% VALLEY WALLS

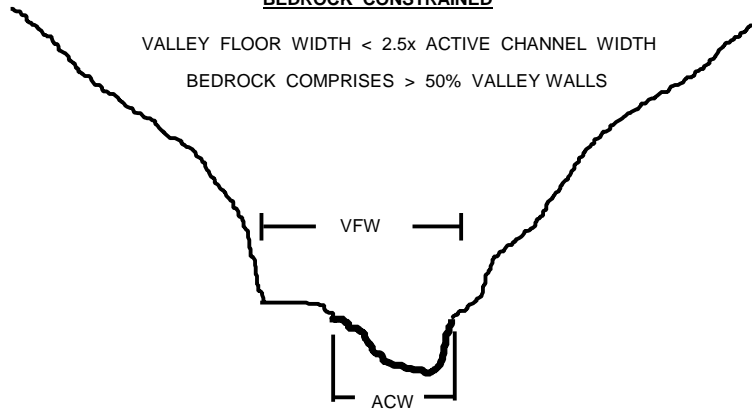

UNCONSTRAINED

VALLEY FLOOR WIDTH > 2.5x ACTIVE CHANNEL WIDTH

FLOOD PRONE WIDTH > 2.5x ACTIVE CHANNEL WIDTH

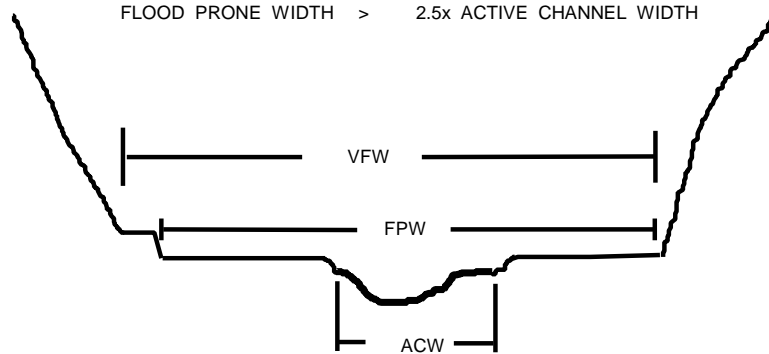

APPENDIX 3: EQUIPMENT CHECK LIST

IN STORAGE BOX:

- ATLAS (Oregon Atlas and Gazetteer. DeLorme Mapping \$14)
- AMPHIBIAN FIELD IDENTIFICATION GUIDE (\$14.95)
- USGS TOPOGRAPHIC MAPS (must have for each stream)
- CAMERA / FILM / MAILER ENVELOPES (Olympus Dateback \$225)
(color slide film and mailers \$90 nine rolls)
- CLINOMETER (Sunto instruments \$125)
- CLIPBOARDS (fiberback \$2, and/or metal \$20)
- COMPASS (\$20)
- GPS unit (recommended \$175 - 300)
- DATA FORMS / FILE BOX (forms from ODFW, box \$5)
- FIBERGLASS MEASURING TAPE (60m metric Kesson \$65)
- FIELD BOOK ("Rite in the Rain" Line Rule or Level \$3)
- FLAGGING TAPE (four rolls blue and white stripe \$8)
- SURVEY METHODS AND INSTRUCTIONS
- THERMOMETER (Pocket Celcius scale \$10)
- VESTS (optional Filson Cruiser Vest \$45 each)
- STORAGE BOX (Rubbermade Action Packer \$20)
- CB RADIO (optional for some crews)
- PENCILS, SHARPIE WATERPROOF MARKER (\$3)
- FIRST AID KIT (\$45)

OTHER:

- DEPTH STAFF (2m long marked every 5cm)
- HATS AND UNIFORM SHIRTS (ODFW personnel only)
- HIP BOOTS (\$60-90 x2)
- WADERS (\$70-110 x 2)
- WADING SHOES (\$45-75 x 2)
- RAINGEAR (\$45-75 x 2)

All equipment must be checked in at the end of the field season. You supervisor will replace hip boots, wading shoe felts, and other equipment that may become worn out during the summer. Keep your supervisor informed of your equipment needs.

APPENDIX 4: EXAMPLES OF COMPLETED DATA FORMS AND BLANK DATA FORMS FOR COPYING

REACH

PAGE: _____ OF: _____

STREAM: _____

CREW: _____

BASIN: _____

USGS 7.5' MAP NAMES: _____

DATE	REACH #	UNIT NUMBER	CHANL FORM	VALLEY FORM	VWI	VEG CLASS		LAND USE		WATER TEMP	STRM FLOW	LOCATION TWN-RNG-SEC-1/4	PHOTO # /TIME	REACH NOTE
						DOM.	SUB-DOM.	DOM.	SUB-DOM.					
													/	

UTM _____

UTM _____

UTM _____

UTM _____

UTM _____

UTM _____

RIPARIAN

PAGE: _____ OF: _____

STREAM: _____

DATE: _____

NAME: _____

UNIT NUMBER	SIDE	ZONE	SURFACE	SLOPE	CANOPY CLOSURE	SHRUB % COVER	GRASS/FORB % COVER	TREE	COUNT (DBH in CENTIMETERS)					RIPARIAN NOTE
									3-15	15-30	30-50	50-90	90+	
	LEFT	1						CONIFER						
								HARDWOOD						
		2						CONIFER						
								HARDWOOD						
		3						CONIFER						
								HARDWOOD						
	RIGHT	1						CONIFER						
								HARDWOOD						
		2						CONIFER						
								HARDWOOD						
		3						CONIFER						
								HARDWOOD						
	LEFT	1						CONIFER						
								HARDWOOD						
		2						CONIFER						
								HARDWOOD						
		3						CONIFER						
								HARDWOOD						
	RIGHT	1						CONIFER						
								HARDWOOD						
		2						CONIFER						
								HARDWOOD						
		3						CONIFER						
								HARDWOOD						

APPENDIX 5: METHODS FOR RANDOM HABITAT SURVEYS

Oregon Plan Monitoring Surveys Aquatic Inventories Project

Introduction:

An important objective of the Oregon Plan for Salmon and Watersheds was to determine current salmon habitat conditions and track trends in habitat over time. In order to accomplish this goal a long-term monitoring program incorporating coordinated stream habitat surveys, juvenile snorkeling inventories and spawning salmon surveys was developed. All field surveys encompass a point randomly selected using a GIS. Methods for the habitat survey portion of the monitoring effort are similar to the basin surveys that have been conducted by the ODFW Aquatic Inventories Project since 1990. Due to the standard survey length of the monitoring sites, some measurements are taken at increased frequency while others are omitted. These survey modifications are specific to the monitoring surveys, not to a comprehensive basin survey.

Site Set-up

It is crucial that the field surveys are set-up correctly. Some sites will be shared by all Oregon Plan monitoring programs during the same survey season and between years. There are some specific guidelines that need to be followed for site set-up to be successful.

- ✓ Surveys need to encompass the point identified for the site.
- ✓ Spawning survey signs may NOT be crossed when setting up a survey. If a spawning survey sign occurs before the point has been surveyed move the survey up to the spawning survey sign. If the spawning survey sign occurs after the point has been surveyed then move the start of the survey further down stream.
- ✓ Include only one homogenous reach in survey (see reach section below)
- ✓ Coordinate with Juvenile Snorkel survey crews to survey common sites together. If it is not possible to coordinate with them, make sure to share survey set up information.
- ✓ If you have questions about the set-up of a site contact your field supervisor or Becky.
- ✓ Clearly mark sites and take GPS readings at start and end points whenever this is possible.

Site Marking

GPS coordinates will be taken at the start and end of the survey and will be recorded on the reach sheet. They will also be saved on the GPS unit with the site code and S for start or E for end. The GPS units will be downloaded at the end of the season to extract stored information.

GPS GCA codes:

N – North Coast

M – Mid Coast

U – Umpqua

C – Mid-south coast (based out of Charleston)

S – South Coast

Example: the GPS unit coding for site Mid-coast 345 should be: start point M345S and end point M345E

Yellow site tags and flagging will be placed at the start and end point of the survey with an aluminum nail. Tags will be marked with stream name, site #, and START or END. Location of the tags will be noted on the reach sheet (e.g. large conifer stump on right). Site tags and flagging should be placed on repeat surveys only when they are missing.

Photos

Photos will be taken at the start of the survey. Other photos may be taken of outstanding features of interest (such as significant barriers, debris flows, large log jams or blow down).

Reach Information

It is the goal of the habitat survey to describe stream conditions that are representative of the point selected in the original sampling design. Therefore, it is best for only one reach to be documented in the field survey. There are instances in which the beginning or end of a survey may be moved in order to accommodate a reach break.

Example: On a 1km survey, if a reach break occurs 100 meters into a survey and the survey point has not been reached move the start of the survey to the beginning of the new reach. If the same condition occurs but the point is surveyed in the first 100 meters then move the survey below your initial survey point and restart the survey so that it ends at the reach break. If you modify the survey reach make sure that the new survey does not cross a spawning survey start or end sign.

While some modification may allow the maintenance of only one reach there are instances when a reach break occurs mid-survey. If a major reach change does occur during the survey, the reach will be recorded as a separate reach and the survey will continue for the full length. Only major changes in channel and valley constraint or major tributary junctions are a reason to call additional reaches.

Habitat Unit 1 form

Flood Prone Width, Flood Prone Height, Active Channel Width, and Active Channel Height will be measured 5 times per survey. It is not necessary to break a unit at exactly these distances if it does not happen naturally. Instead, conduct these measurements at the beginning (or end) of the unit closest to the desired distance.

- For 1 km sites these will be taken at 0, 250, 500, 750 and 1000m
- For 0.5 km sites these will be taken at 0, 125, 250, 375 and 500m

All unit lengths and widths will be measured. Unit length will be measured up the center of the channel or following the thalweg in pools. The thalweg is defined as the portion of the stream carrying the most flow. In lateral pools this may be to the right or left of the center of the

stream. Unit width will be measured at the point of average unit width. In highly variable or long units, multiple widths will be measured and averaged together. If unit lengths or widths are estimated they must be noted.

In order to ensure an adequate number of habitat units, maximum lengths are:

- The maximum length of fast-water units for 1 km sites is 50m(+5m).
- The maximum length of fast-water units for 0.5 km sites is 25m(+5m).
- There is no maximum length for slow water units (pools).

If a unit will naturally end within 5 m of the maximum unit length the unit may be extended to the natural end.

Example: In a 1 km survey, if a rapid that is 55 m long is followed by a lateral scour pool, there is no need to break the rapid unit into 2 units one 50 m in length and one 5 m in length. If the rapid unit is 60m in length, 2 units would need to be identified and recorded.

Riparian Survey

Riparian transects will be conducted at three (3) points along each survey. As with channel metrics, it is not necessary to break a unit at these measurements. Conduct the transect at the beginning of the unit closest to the desired distance.

- For 1 km sites these will be taken at approximately 250, 500, and 750m.
- For 0.5 km sites these will be taken at approximately 125, 250, and 375m.

APPENDIX 6: FISH INVENTORY PROTOCOL

Oregon Plan Monitoring Surveys Aquatic Inventories Project

Introduction

In 1998, the Oregon Plan for Salmon and Watersheds (OPSW) mandated that the Oregon Department of Fish and Wildlife (ODFW) establish annual surveys to monitor stream habitat and fish populations in Oregon coastal streams. At sites upstream of the known distribution of coho, fish are sampled with electrofishing gear to assess species composition and distribution.

The Effect of Pulsed Direct Current on Fish

Electroshocking surveys are conducted with Smith-Root backpack electrofishers that discharge direct pulsed current. When the button on the probe (anode) is pushed, an electrical circuit is completed through the water when the current flows from the negative cathode (rattail) through the water and then to the positively charged anode (probe). Fish that are on the periphery of a weak electrical current experience mild nerve excitation but still retain control of swimming ability and will escape from the field. Those under a strong electrical field experience a progressive series of reactions that culminate in immobilization. The polarized nature of body musculature often causes fish to curve toward and face the anode, but the initial orientation of fish in the electrical field results in varied directional responses. Spasmodic undulations of the musculature induced by the electrical field may also result in involuntarily swimming (electrotaxis) towards the anode probe. As fish move closer to the anode probe, they experience increased intensity of electrical current. Above a certain intensity, body muscles become cramped and fish are immobilized.

Fish close to the anode probe are quickly immobilized and may not exhibit electrotaxis. Larger fish are more easily immobilized than smaller fish because they present a greater amount of nerve tissue to the electrical field at a given distance from the anode probe. In addition to voltage the frequency and wavelength of pulsed direct current has different effects on muscles depending on fish size, species, water temperature and conductivity. Smaller fish generally require higher pulse frequencies to become immobilized. A minimum frequency exists below which fish will not be immobilized.

Fish recover the ability to swim quickly after electroshocking if the applied current is not too strong and the amount of time they are exposed to the electrical field is short. However, the fish may experience physiological stress for several days following shocking. Injury (damage to swim bladders, muscles, and skin; fractured vertebrae; and bleeding have been reported) or death can result if excessive current is applied.

The zone of potential fish injury is 0.5 m from the anode. Care should be taken in shallow waters, undercut banks, or where fish can be concentrated because in such areas the fish are more likely to come into close contact with the anode (NMFS, 2000).

Crew members should carefully observe the condition of sampled fish. Dark bands on the body and longer recovery times are signs of injury or handling stress. When such signs are noted, the settings for the electrofishing unit should be adjusted. *Sampling should be terminated if injuries or abnormally long recovery times persist even after shocker settings have been reduced.*

Safety

The use of electrofishers can be dangerous. Some fatalities have occurred with older electrofishers that lacked tilt switches. Common sense will eliminate most of the potential for injury. Prevent exposure to the electrical field. Use nets with insulated metal handles. Wear standard weight waders or boots that have no leaks.

Rubber gloves are required to be worn while electrofishing. Replace ripped or overly worn gloves. Never place bare hands in the water unless it is completely understood that the electrical current is off and the probe is removed from the water.

Stunned fish frequently need to be extracted from crevices in the streambed. Before attempting to pick up a fish, have a well understood convention with the electrofisher operator, such as the netter saying "off" and having "off" repeated by the operator after the current is stopped and the probe lifted from the water. Resume electrofishing only after both parties give an "on" command. When reaching into crevices, use only one hand and keep the other arm well out of the water. This prevents passing an arc of current through your chest. Also, there is a chance of shock if you touch the probe in the "on" position at the same time you are touching the box on the backpack.

Electrofishing methods

Technique

Electrofishing has the potential to harm or to cause direct mortality of fish. Electrofishing can also be hazardous to the survey crew if not performed correctly. Use the least amount of voltage and lowest frequency pulse that effectively immobilizes fish (see section below on Electrofishing Methods). This decreases stress and chance of injury to the fish. It also extends the amount of time on the battery charge. Increase voltage when target fish are small or when the conductivity of the water is low. Decrease the voltage and frequency if large fish are observed in the habitat unit. *Do not sample if adult salmon are observed in the unit.*

Sample at least 3 pools and 3 fastwater units totaling a minimum of 60 meters stream length. Record the fish collected in the first pool by species and size. Sample at least 15 meters of the fastwater unit immediately above the pool and record the fish captured. Walk upstream to the next pool and sample it and the fastwater unit above. Consecutive sampling is preferred. Continue sampling until 3 pool – fastwater sequences have been sampled. If a fish species or life history stage not observed in the first 4 units is captured in the 5th or 6th unit, sample another pool and fastwater unit. In small streams with low flow, you may have to walk a considerable distance to locate pools. In larger streams with long habitat units, you may need to subsample within unit types as well as sample a variety of unit types. If you detect a potential fish barrier in the habitat survey, electrofish above and below the barrier to determine if it impedes fish passage.

Release netted fish far enough downstream to be outside the electrical field. Carefully release fish back into the water; fish should not be exposed to air for more than a few seconds or latent mortality will likely occur.

If you are unable to identify the fish, take a close-up photo or preserve a few individuals in ethanol for later identification. Write the date, stream name, sample site code, and name of the sampling crew members on the label in the jar or ziplock. Note on the data form that a collection was made at that site.

Survey Guidelines

(Information in this section taken from Rodgers 2001 unless otherwise cited)

Do not shock when water temperatures are above 18 C (65F) or expected to be above this temperature prior to completing the electrofishing. If water temperatures are appropriate in the morning, but you anticipate that they will increase later in the day, electrofish before you complete the habitat survey.

Measure the water conductivity and record it on the Fish Survey data form. High conductivity (over 2,000 microSiemens/cc) allows the electric current to spread throughout the water, decreasing the risk to fish health because most of the current flows through the water and not the fish. With higher conductivity readings use low voltages. Water conductivity may be higher in agricultural areas due to chemicals applied to fields and associated runoff. Conductivity of water also increases with increasing water temperature (Smith-Root 1998)

Smith Root electrofishers allow for adjustment of voltage, waveform, and frequency. Start with a setting of H-4 and 200 volts if in shallow pools; H-4 and 300 volts if sampling in deeper pools (>0.8m). Note that a pool for shocking may be smaller than pools identified in a standard habitat survey. If damage to fish (visible burn marks, extended spasms or long recovery periods) is occurring, decrease voltage to 100V. If fish continue to be injured, change settings to G-3 and 100V. If damage continues, try F-3 and 100V.

Increase voltage to 300V at H-4 if only small fish are being netted and larger fish are observed swimming away from the probe or fish are not stunned long enough to net. If either of these conditions continue, increase settings to I-4 and 200V. If this isn't catching fish, increase voltage to 300V and I-4. **Do NOT increase voltage beyond 300V.** Make sure to record shocker settings on the Fish Survey form.

The preferred method to prevent accidental mortality is to "attract" fish to the ring rather than actually "rolling" them. Keep the trigger on while "attracting" or "pulling" fish and netting them. Release trigger if you are rolling fish before you are able to net them.

The best way to get fish within an effective radius of the anode probe is to "surprise" them. Position the probe in a new area while it is turned off, turn it on only after it is in place. Sweeping a live probe about the stream merely introduces the weak border of the electrical field to new areas and fish will easily detect and escape the field. The stream should be covered systematically, moving the anode in a herringbone pattern through the water. Do not electrofish one area for an extended period. Continue shocking the habitat unit until the first pass is completed OR until at least one juvenile coho has been captured. Electrofishing of a stream must be terminated once a coho has been captured and positively identified.

Tips about the anode:

- *Do not use a net on the end of the ring.*
- *Wrapping the ring with cording may reduce damage to fish. Be sure to check the wrapped ring periodically for corrosion.*
- *Larger rings are better than smaller rings, they reduce the power gradient near the ring.*
- *Keep ring clean using a Scotch-brite pad suitable for Teflon. Do not use steel wool. Ring are fragile so be careful not to break them when cleaning.*

Tips about the cattode:

- *Add more area effected by electrical current by keeping the tail behind you in the same unit you are shocking. Be careful the cathode is not close to the anode and do not allow them to touch.*

Fish Survey Data Form

(most of the information in this section taken from "Methods from Stream Fish Inventories" 1998)

Header Information

Crew: Names of surveyors.

Stream name: Spell out the complete name of the stream being surveyed. Include the site identification number and monitoring area (MA) code.

USGS Map: Name of the USGS. 7.5 minute topographic quad.

Basin: Use the name of the large river commonly used to describe a region. For example, use McKenzie R as the basin name when sampling Lookout CR, not Willamette or Columbia.

Date: MM/DD/YY.

Notes: Additional information concerning sample site location (particularly relative to culverts or other potential barriers), type of ownership, and access roads or trails. Comments on the weather, cloud cover or precipitation, visibility and habitat condition can also be made.

UTM Start: Record the UTM coordinates at the beginning point of the fish survey.

UTM End: Record the UTM coordinates at the end point of the fish survey.

Map Code: Record the site's code including monitoring area and site id number (such as U1556 – for Umpqua site #1556). Be sure to mark all sites on topo maps and be as accurate as possible in marking sample sites on maps.

Active Channel Width: Distance across channel at "bank full" annual high flow estimated from change in vegetation, slope break, or high water mark. Sum the width of all active channels in multichannel situations.

Active Channel Height: Vertical distance from the stream bottom to the top of the active channel.

Stream Flow:

DR DRy

PD Puddled. Series of isolated pools connected by surface trickle or subsurface flow.

LF Low Flow. Surface water flowing across 50 to 75 percent of the active channel surface.

MF Moderate Flow. Surface water flowing across 75 to 90 percent of the active channel surface.

HF High Flow. Stream flowing completely across active channel surface but not at bankfull.

BF Bankfull Flow. Stream flowing at the upper level of the active channel bank.

FF Flood Flow. Stream flowing over banks onto low terraces or floodplain.

Water Temp: Degrees Centigrade or Fahrenheit; indicate scale used.

Gear/Method: Indicate method of sampling (i.e. snorkel, seining, or electrofishing). When electrofishing, indicate voltage setting of electroshocking unit.

Photo number and time: Take a photograph that shows the stream and riparian zone typical of the reach sampled. Record the exposure number and the time shown on the camera back. This can be the same photo used for the habitat survey.

Location: Township, range, and 1/4 section at the start of the fish survey site. Use following format: T10S R5W S22 SE. Draw a rough sketch of the stream as it appears in the topo map section in the upper right corner of the data form (see example).

Site Detail and Fish Species Information

Survey Number: The number of the unit sampled during habitat survey (if known). Not particularly important for Oregon Plan sites.

Sequence Number: The sequential number describing the order that channel units were sampled. Sample a minimum of 6 units and at least 60 meters.

Unit or Channel Type: Use the habitat types listed in the physical habitat survey methods.

Unit Length: Estimated length of each habitat unit or channel type sampled.

Depth: Maximum depth in pools, modal or typical depth in glides and other fast water habitat unit types.

Fish Code: Use the standard codes for the following species. For species not on the list, a code should be invented and an explanation of the code must be given in the note column and on every data form the invented code is used on.

standard abbreviations:

BG	bluegill	LAM	lamprey
BLB	black bullhead	MSU	mountain sucker
BR	brown trout	OC	Oregon chub
BRB	brown bullhead	PK	pumpkinseed
BSU	bridgelist sucker	PM	peamouth
BT	brook trout	PS	pink salmon
BUT	bull trout	RB	rainbow trout
CC	channel catfish	RSS	redside shiner
CH	chinook salmon	RT	redband trout

CLM	chiselmouth	SB	smallmouth bass
CO	coho salmon	SS	sockeye salmon
CS	chum salmon	ST	steelhead
CSU	largescale sucker	SU	sucker
CT	cutthroat trout	WF	mountain whitefish
D	dace		

non-standard abbreviations:

AM	ammocoetes	PGS	pacific giant salamander
AS	Atlantic salmon	RTS	reticulate sculpin
ATF	adult tailed frog	RO	roach
BD	black dace	RSN	rough skin newt
BTH	brook/bull hybrid	SH	shiner spp.
C	crappie	SKB	stickleback
CF	crayfish	SR	sandroller
COT	sculpin	SPD	speckled dace
CP	carp	SQ	northern squawfish
CTH	cutthroat hybrid	SNF	sunfish
FRG	frog (species unknown)	SF	salmonid fry (age 0+)
JSU	Jenny lake sucker	SAL	salamander
LB	largemouth bass	TC	tui chub
LND	longnose dace	TF	trout fry (age 0+)
MF	western mosquitofish	TFT	tailed frog tadpole
MMS	Malheur mottled sculpin	UT	unknown trout
MS	mottled sculpin	US	unknown salmonid
X	no fish found	YP	yellow perch

Count: Tally of the number of fish grouped by species and size class.

Note: Indicate whether length was estimated (E) or measured (M) in comments column. Write measured lengths in all columns as needed. Also indicate pass number when separate passes are made within a single habitat unit (ie: E-1 for estimated 1st pass).

Electrofisher Troubleshooting

Malfunction of the electrofishing system may occur in the field and can be very frustrating. The following tips can help to resolve problems with the equipment.

Problem: Unit won't shock fish.

Possible Solutions:

1. Dirty anode ring. Clean ring with wire wheel or abrasive pad. DO NOT USE SANDPAPER!
2. Broken wire in anode pole. Try a different pole. See section on ANODE TESTING for testing anode poles.
3. Broken cathode (tail). Try a different cathode. See section on CATHODE TESTING for testing tails.

4. Battery weak or dead. Check voltmeter on front of unit with output activated. Replace battery if necessary.
5. Loose connection at battery terminals. Tighten connection if possible. If connection is broken or burned return for repair.
6. No output. Return unit for repair.
7. Unit is tilted at too steep an angle. Tip over switch is turning off unit. Make sure to stand upright when shocking.
8. Rattail is not in water. Both the probe and rattail must be in the water for a circuit to be completed.

Problem: Unit overloads.

Possible Solutions:

1. Output voltage set too high. Reduce output voltage setting.
2. Pulse width or frequency control set too high. Reduce setting.
3. Anode and cathode too close together. Increase distance between electrodes.
4. Metallic object in the water or stream bed near the shocker.

Problem: Relay clicks on and off when output activated.

Possible Solutions:

1. Broken wire in anode pole curl cord. Try a different pole.
2. Weak battery. Replace.
3. Bad connection at battery terminals. Tighten connection is possible. If connection is broken or burned return for repair.

Problem: On/Off circuit breaker trips when unit is turned on.

Possible Solution:

1. Battery connected backwards. Return unit for repair.

Anode Testing

1. Disconnect pole from shocker.
2. Connect red lead of ohmmeter to pin A in plug on end of curl cord.
3. Connect black lead of ohmmeter to anode ring or bottom of pole.
4. Set ohmmeter to read 200 ohms full scale.
5. The ohmmeter should read near zero ohms regardless of pole switch position if not the pole is bad. Shake the curl cord during this test. If the reading changes the pole is bad.
6. Connect the red lead of the ohmmeter to pin B in the pole connector.
7. Connect the black lead of the ohmmeter to pin C in the pole connector.
8. The ohmmeter should read infinite resistance until the pole switch is pressed. if not the pole is bad. Shake the curl cord during this test, if the reading changes the pole is bad.
9. Press the pole switch. The ohmmeter should read near zero ohms. If not the pole is bad. Shake the curl cord during this test, if the reading changes the pole is bad.
10. Test between each pin in the plug and the metal shell of the plug. The ohmmeter should read infinite resistance, if not the pole is bad.

Cathode Testing

1. Disconnect cathode from shocker.
2. Connect red lead of ohmmeter to pin A in plug on end of cathode.
3. Connect black lead of ohmmeter to bare cathode cable.
4. Set ohmmeter to read 200 ohms full scale.
5. The ohmmeter should read near zero ohms. If not the cathode is bad. Pull on the cable, if the reading changes the cathode is bad.
6. Connect the red lead of the ohmmeter to pin B in the cathode plug.
7. Connect the black lead of the ohmmeter to pin C in the cathode plug.
8. The ohmmeter should read near zero ohms, if not the cathode is bad.
9. Test between each pin in the plug and the metal shell of the plug. Ohmmeter should read infinite resistance, if not the cathode is bad.

Batteries

Our Smith-Root backpack electroshockers are powered by a 24 volt gel cell battery. Following some simple procedures can prolong a battery's service life. For instance:

1. Recharge batteries after every use.
2. Protect batteries both in use and in storage by periodically charging them during cold weather. Cold temperatures reduce the amount of cranking capacity a battery can offer so it is best if batteries are not left in the cold.
3. Always place batteries on a wood surface when in use or in storage. If left set directly on the ground, the battery will discharge.

References

Methods for Stream Fish Inventories. 1998. Oregon Department of Fish and Wildlife-Aquatic Inventories Project, Natural Production Section, Corvallis Oregon. Version 7.1, July 1998.

NMFS Guidelines for Electrofishing Waters Containing Salmonids Listed Under the Endangered Species Act. 2000. National Marine Fisheries Service, National Oceanic and Atmospheric Administration.

Rodgers, Jeff. 2002. Protocols for Conducting Juvenile Coho Salmon Surveys in Oregon Coastal Streams. Oregon Department of Fish and Wildlife, Corvallis Oregon.

Rodgers, Jeff. 2001. Personal Communication.

Smith-Root Backpack Electrofishers. 1998. Smith-Root, Inc. Vancouver, WA Rev. 03.